

TCM-5000EV

SERVICE MANUAL

US Model
Canadian Model
AEP Model
UK Model
E Model



SPECIFICATIONS

Recording system 2-track 1-channel monaural

Speaker Approx. 9.2 cm (3 $\frac{5}{8}$ inches) dia.

Fast winding time Approx. 2 min. with Sony C-60 cassette

Playback speed -20% adjustable
+40%

Frequency response 90-9,000 Hz
VOR recording: 300-5,000 Hz

Inputs Microphone input (minijack)
sensitivity 0.2 mV (-72 dB) for low impedance microphone
Mixing microphone input (minijack)
sensitivity 0.44 mV (-65 dB) for low impedance microphone
Line input (minijack)
sensitivity 0.06 V (-22 dB)
input impedance 100 kilohms

Output Earphone (minijack)
for 8 to 300 ohm earphone or load impedance 10 kilohms or higher

Other jack Remote control jack

Power output 700 mW (at 10% harmonic distortion)

Power requirements 6V dc
4 batteries size C (IEC designation R14)
or optional Sony BP-16H rechargeable battery pack
DC IN 6V jack accepts:
optional Sony AC-61 ac power adaptor (in the USA) or optional AC-12 ac power adaptor (in Canada) for use on 120V ac, 60 Hz (US, Canadian Model)
optional Sony AC-122 ac power adaptor (available in the United Kingdom and European countries) for use on 110, 127, 220 or 240 V ac, 50 Hz (AEP, UK, E Model)
optional Sony AC-122 ac power adaptor (available in other countries) for use on 110, 120, 220 or 240 V ac, 50/60 Hz (AEP, UK, E Model)

optional Sony DCC-127A car battery cord for use on 12V car battery
optional Sony DCC-240 car battery cord for use on 24V car battery

Battery life (US, Canadian Model)

Batteries	Recording	Playback
Sony SUM-2(NS) New Super or Eveready Heavy Duty No. 1235 batteries	Approx. 8 hours	Approx. 7 hours
Eveready No. E93 alkaline batteries	Approx. 20 hours	Approx. 20 hours

Battery life (AEP, UK, E Model)

Batteries	Recording	Playback
Sony SUM-2(NS) New Super batteries	Approx. 8 hours	Approx. 7 hours
Sony Eveready AM2 alkaline batteries	Approx. 20 hours	Approx. 20 hours

Dimensions Approx. 270.8 × 58.4 × 154 mm (w/h/d)
(10 $\frac{3}{4}$ × 2 $\frac{3}{8}$ × 6 $\frac{1}{8}$ inches)
incl. projecting parts and controls

Weight Approx. 1.45 kg (3 lb 4 oz)
incl. batteries

CASSETTE RECORDER
SONY®



TC

LOCATION AND FUNCTION OF CONTROLS

- ① **PEA (pre-end alarm) indicator**
Flickers a few minutes before the end of the tape during recording.
- ② **▼ LOCK (eject lock) lever**
To lock the cassette compartment lid.
- ③ **▲ EJECT button**
- ④ **Tape operation mode select buttons**
 - ◀ **REVIEW/REW (rewind) button**
 - **STOP button**
 - ▶ **PLAY button**
 - ▶▶ **CUE/FF (fast forward) button**
 - **RECORD button**
 - || **PAUSE button**
- ⑤ **Tape counter and RESET button**
To set the counter "000", press the RESET button.
- ⑥ **SPEED CONTROL**
Adjusts the playback speed.
- ⑦ **tone control**
Adjusts the playback tone quality. Turn to HIGH for more treble, or LOW for less treble.
- ⑧ **MONITOR selector**
Selects the sound to be monitored through the earphone during recording.
- ⑨ **REC MODE (recording mode) selector**
Selects automatic recording (AUTO), Sony voice-operated recording (VOR) or manual recording (MANUAL).
- ⑩ **REC/PB VOLUME/VOR SENS (recording level/playback volume/VOR sensitivity) control**
Adjusts the recording level of the built-in microphone, MIC ① jack or LINE IN jack with the REC MODE selector set to MANUAL; playback volume; or the recording level to activate the VOR recording with the REC MODE selector set to VOR.
- ⑪ **MIC ② LEVEL control**
Adjusts the recording level of the microphone connected to the MIC ② jack.
- ⑫ **LEVEL/BATT (level/battery) meter**
Indicates recording level during recording, playback level during playback, and shows battery condition when the BATT CHECK/LIGHT button is depressed while the set is operating.
- ⑬ **MIC (built-in microphone)**

- ⑭ **BATT CHECK/LIGHT (battery check/memory light) button**
While this button is depressed with the set in operation, the meter shows the battery condition. The meter will be illuminated for about 10 seconds when this button is once pressed.
- ⑮ **REMOTE control jack**
Accepts an optional remote control, foot switch or the thinner pin of a 2-pin plug microphone with remote tape stop/start facility.
- ⑯ **MIC ① jack**
Connect an optional external microphone.
- ⑰ **VOR (voice-operated recording) indicator**
Lights up when the tape is being recorded in VOR recording.
- ⑱ **EARPHONE jack**
- ⑲ **LINE IN jack (minijack)**
Used for recording from another tape recorder, etc.
- ⑳ **MIC ② jack**
Connect an external microphone for mixing.
- ㉑ **Projection for shoulder strap**
To attach the supplied shoulder strap, see back cover.
- ㉒ **DC IN 6 V jack (left side)**

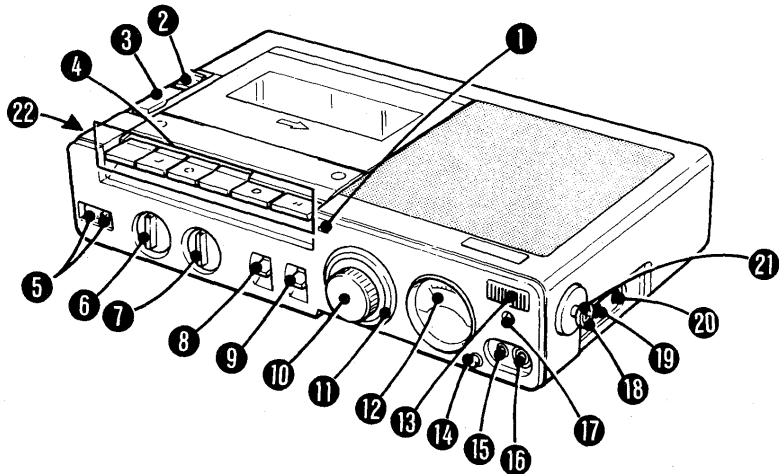

FEATURES

- **Sony voice-operated recording system using the BBD (Bucket Brigade Device) IC** starts and stops recording automatically according to your preset level.
- **Three-head system** which enables you to monitor the recorded sound while actual recording.
- **Pre-end alarm system** to warn you when the tape is about to run out.
- **Auxiliary microphone jack** for record mixing.
- **Playback speed control plus cue and review functions** to quickly catch and write down the tape contents.
- **Eject lock mechanism** prevents accidental opening of the cassette compartment lid.
- **Four different power sources:** batteries, house current, rechargeable battery, and car battery.

Sony voice-operated recording system

In Sony voice-operated recording system, the tape runs only when the sounds higher than a set level are picked up and stops automatically if the level of the sounds become lower than the set level. The VOR indicator lights when recording is being made.

Once you have started the recording with the REC MODE selector set to VOR, you need not press the ■ STOP or || PAUSE button when there is no sound. In addition, you can listen to the tape recorded with this system smoothly, as it does not have long blank spaces.

The BBD (Bucket Brigade Device) IC used in this recorder ensures recording without cutting off the starting point.

Chip components

Chip components include resistors, capacitors, transistors, diodes, coil and adjustable resistors.

In this section, the types of resistors, ceramic capacitors, transistors and diodes which are used most frequently will be described.

Dimension of transistors and capacitors

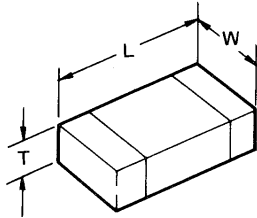

(Unit: mm)

Type	L	W	T
3216	3.2	1.6	0.45 ~ 0.6
2125	2.0	1.25	0.35 ~ 0.5

Identification

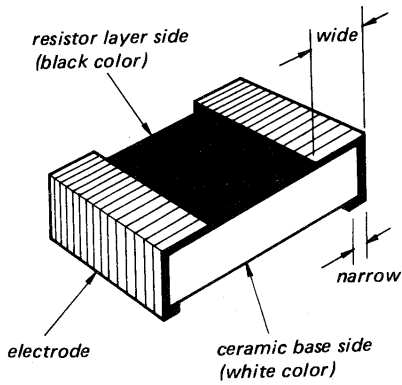

Resistor

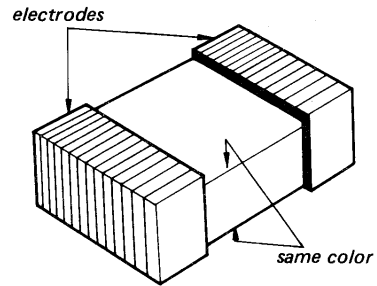

Laminated Ceramic Capacitor

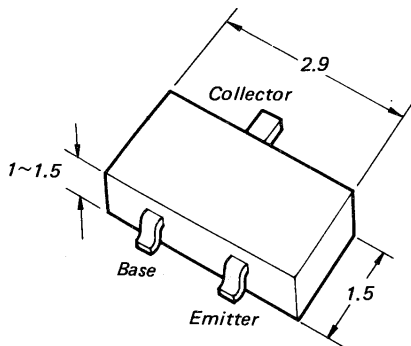

Transistor

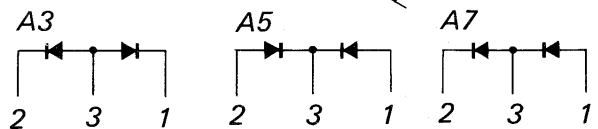
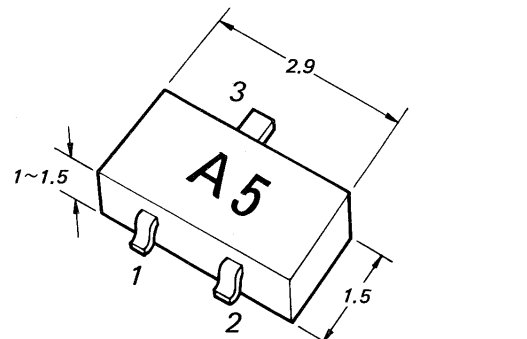

Diode

Replacing chip components

All chip components should be connected and disconnected, using a tapered soldering iron [temperature of the iron tip: less than 280°C (536°F)], a pair of tweezers and braided wire.

Precautions for replacement

1. Do not disconnect the chip component forcefully. Otherwise, the pattern may peel off.
2. Never re-use a disconnected chip component. Dispose of all old chip components.
3. To protect the chip component, heating time for attaching the component should be within 3 seconds.

○ Removing chip components

(1) Removing solder at electrode

Remove the solder at the electrode, using a thin braided wire. Do not remove the solder of the part (chip component) attached adjacent to the electrode.

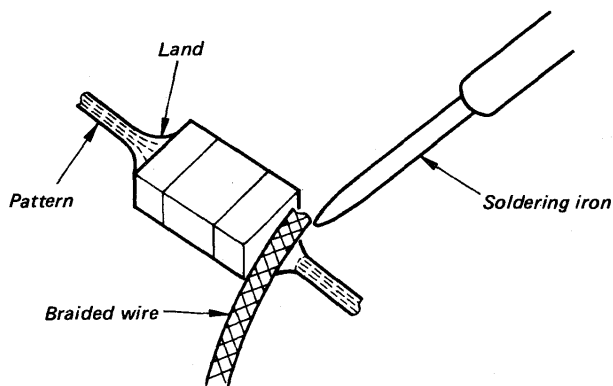

(2) Disconnecting chip components

Turn the tweezers with the soldering iron alternately applied to both electrodes, and the chip component will be disconnected. Take careful precautions while disconnecting, because if the chip component is forcefully removed the land may peel off. Never re-use a disconnected chip component.

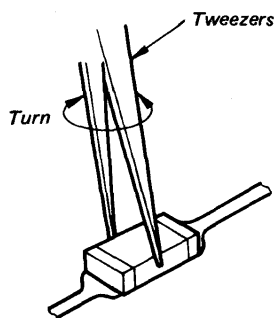

(3) Smoothing the soldered surface

After disconnecting the chip component, remove the solder by using a braided wire to smooth the land surface.

○ Connecting chip components

The value of chip components is not displayed on the main body. Take due precautions to avoid mixing new chip components with other ones.

(1) Applying solder to land on one side

Apply a thin layer of solder to the land on one side where the chip component is to be connected. Too much solder may cause bridging.



(2) Speedy soldering

Hold the chip component at the desired position, using tweezers, and apply the soldering iron in the arrow-marked direction. To protect the chip component, heating time should be within 3 seconds.

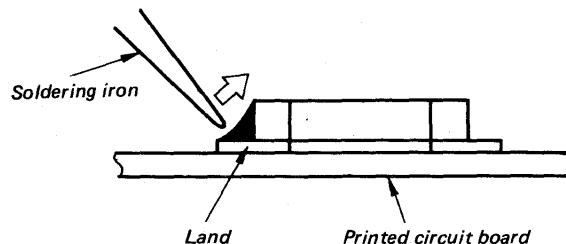

(3) Speedy soldering of electrode on the other side

Solder the electrode on the other side in the same way as in (2) above.

1-1. BLOCK DIAGRAM

SECTION 1
OUTLINE

TCM-5000EV TCM-5000EV

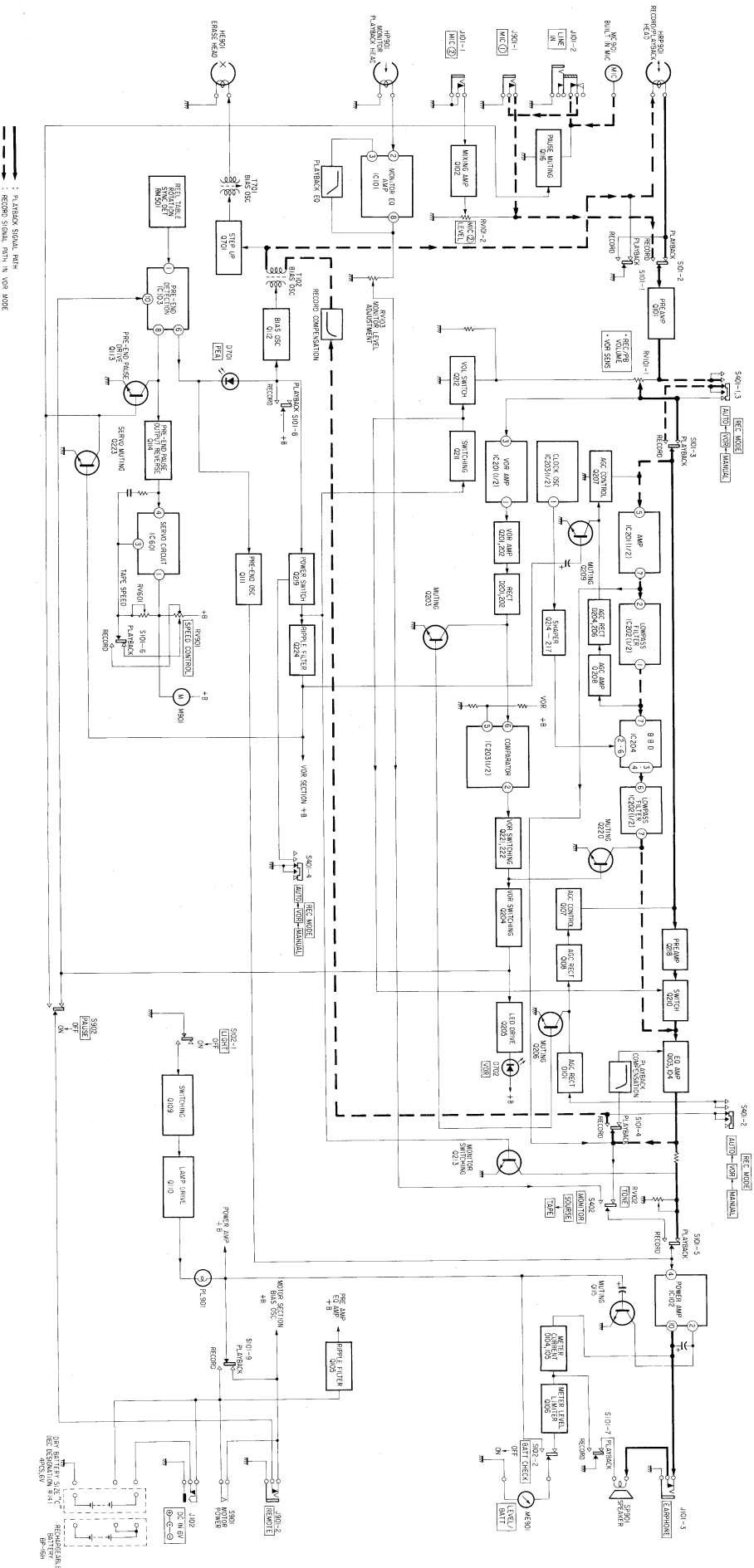

TCM-5000EV TCM-5000EV

SECTION 2 DISASSEMBLY

Note: Follow the disassembly procedure in the numerical order given.

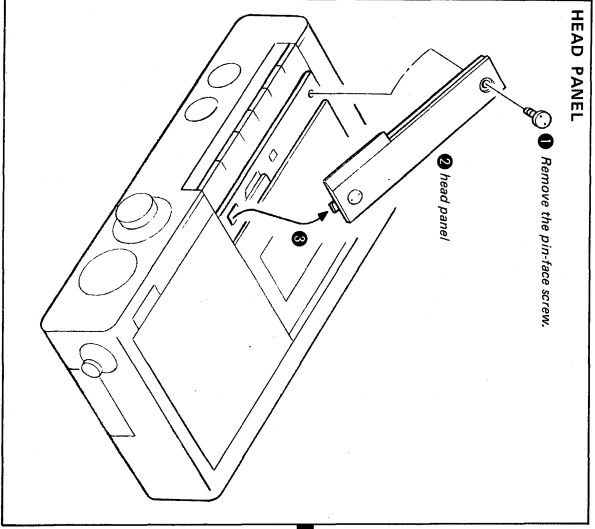
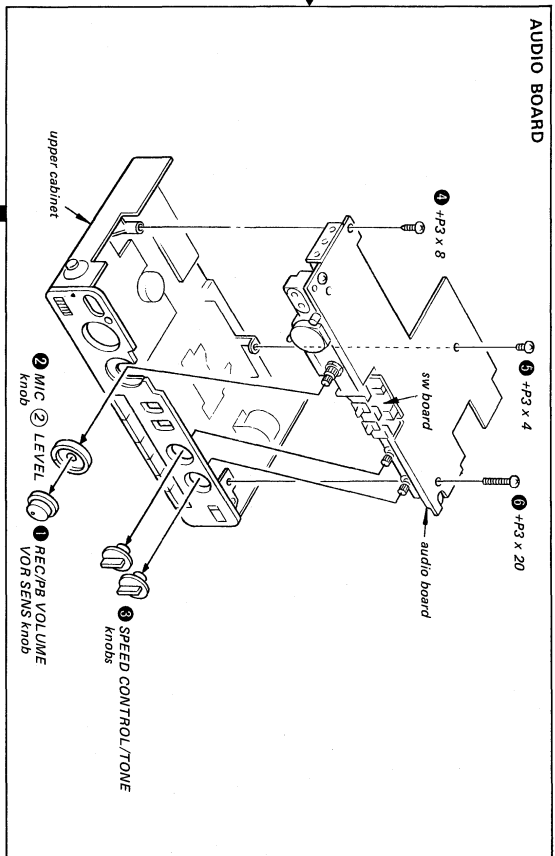
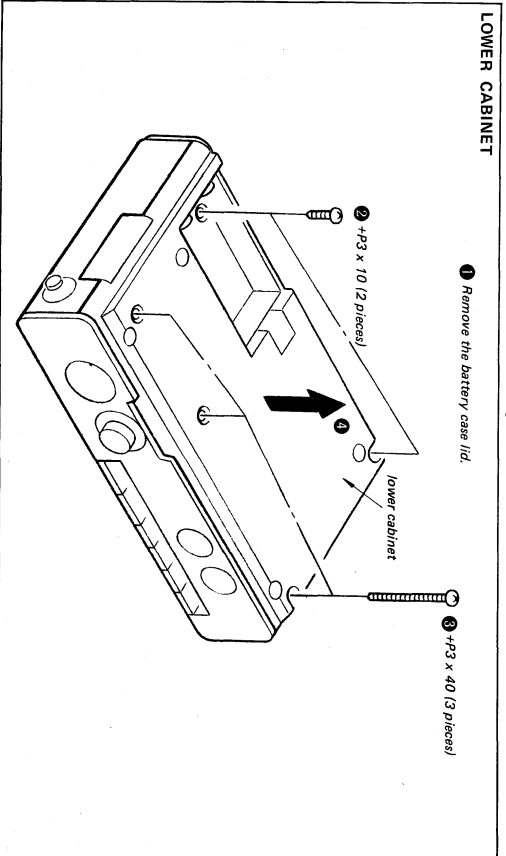

Record/Playback Head and Monitor Head Azimuth Adjustment can be performed. (See Page 13 and 14.)

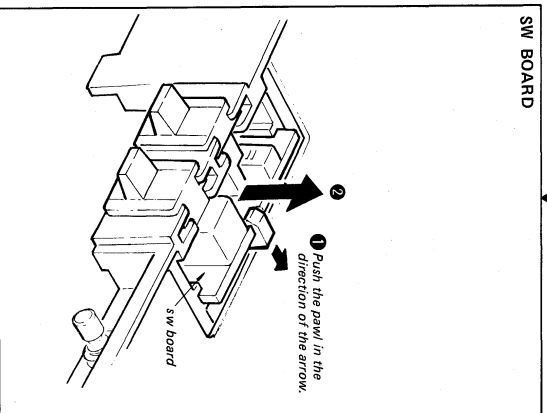
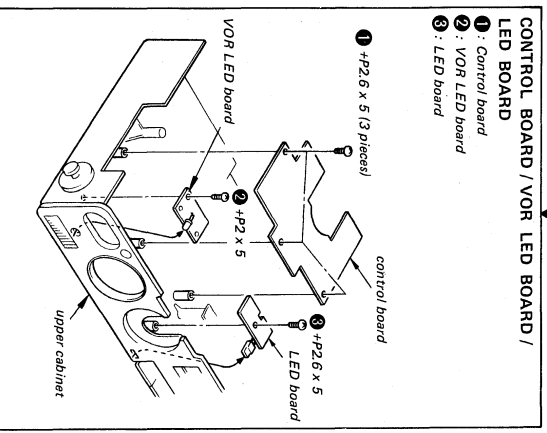

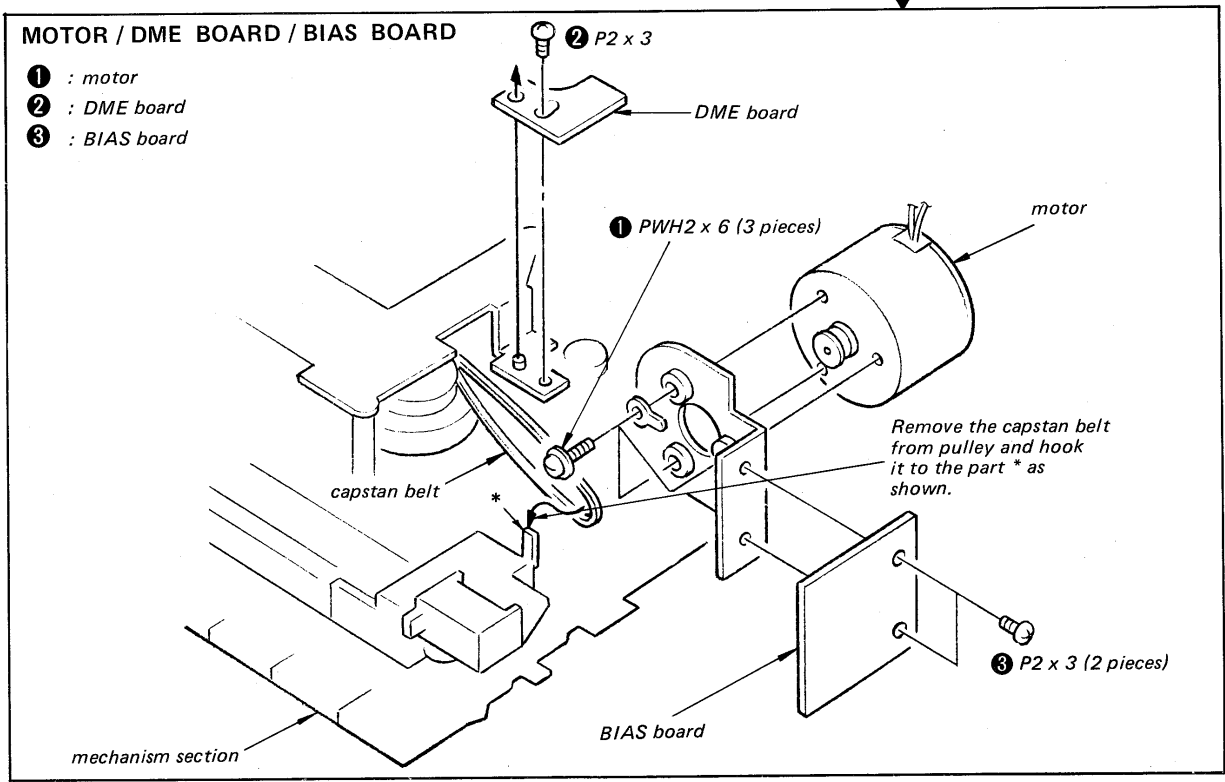
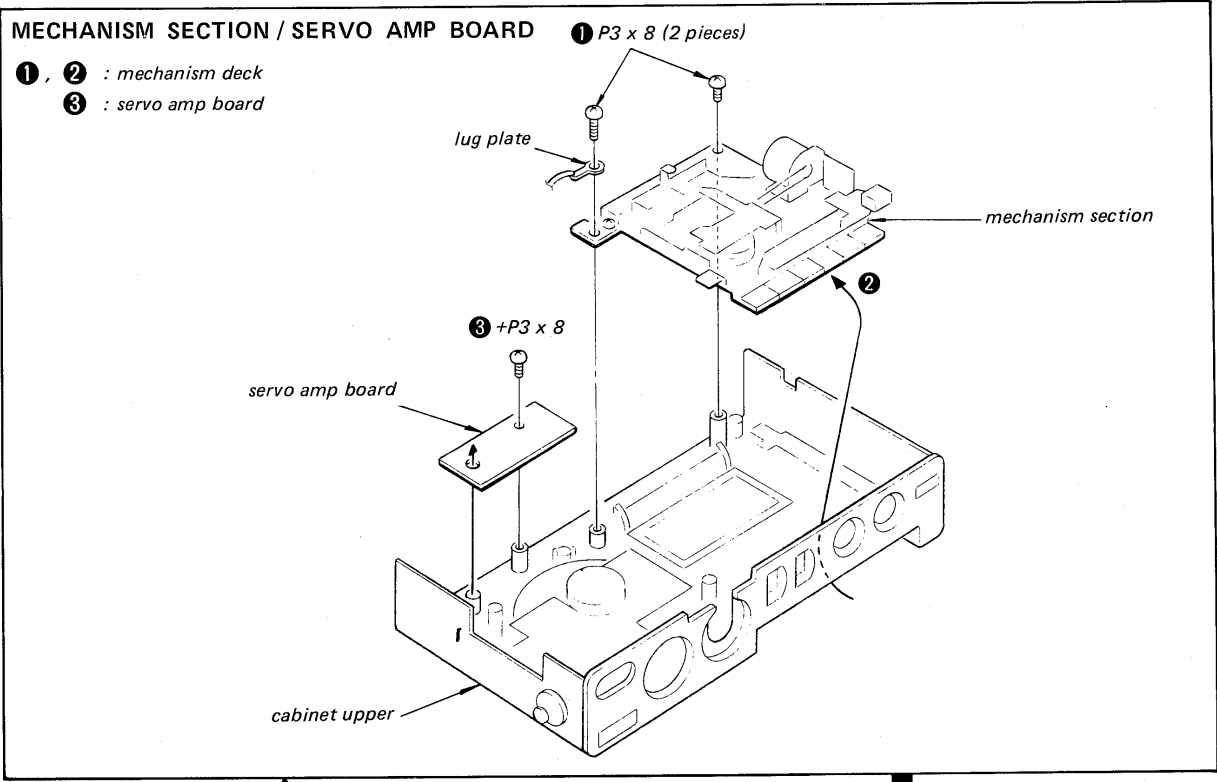

**RECORD / PLAYBACK HEAD / MONITOR HEAD /
ERASE HEAD / PINCH LEVER**

- ①, ② : record/playback head
- ③ - ⑤ : monitor head
- ⑥ : erase head
- ⑦, ⑧ : pinch lever

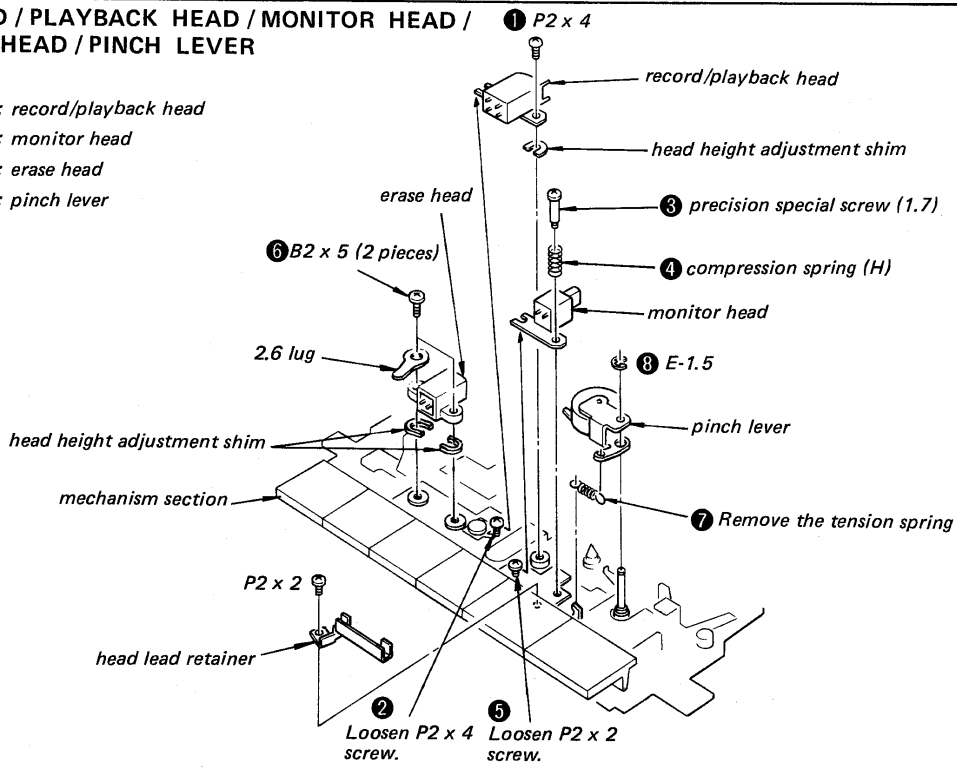

BELTS REPLACEMENT

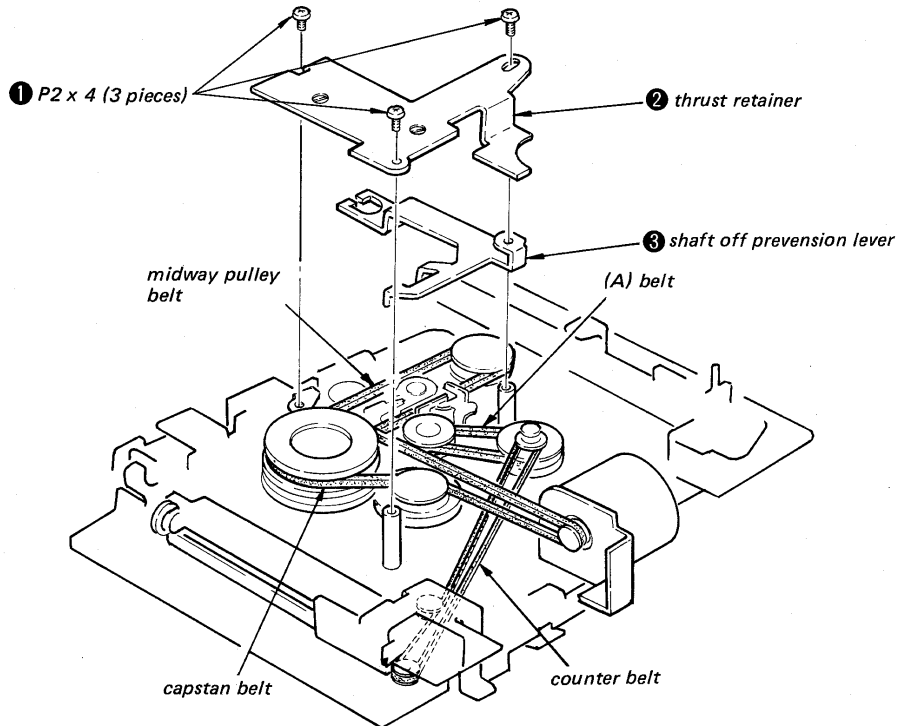

SECTION 3 ADJUSTMENTS

3-1. MECHANICAL ADJUSTMENTS

PRECAUTION

1. Clean the following parts with a denatured-alcohol-moistened swab:

record/playback head	pinch roller
erase head	rubber belts
monitor head	idlers
capstan	
2. Demagnetize the record/playback head with a head demagnetizer. (Do not bring the head demagnetizer close to the erase head.)
3. Do not use a magnetized screwdriver for the adjustments.
4. After the adjustments, apply suitable locking compound to the parts adjusted.
5. The adjustments should be performed with the rated power supply voltage unless otherwise noted.

Torque Measurement

Torque	Meter Reading	Torque Meter (Cassette-type)
FWD torque	25 – 45 g·cm (0.35 – 0.63 oz·inch)	CQ-102B
FF-REW torque	more than 70 g·cm (more than 0.97 oz·inch)	CQ-201B
FWD back tension	5 g·cm	CQ-102B
tape tension	more than 100 g (more than 3.52 oz)	CQ-403A

Pinch Roller Pressure Adjustment
— Playback Mode —

② Slowly return the pinch roller and read the spring scale just when the pinch roller starts rotating. (The capstan should first contacts here.)

center
capstan
pinch roller

① spring scale
200 – 300 g
(7.04 – 10.56 oz)

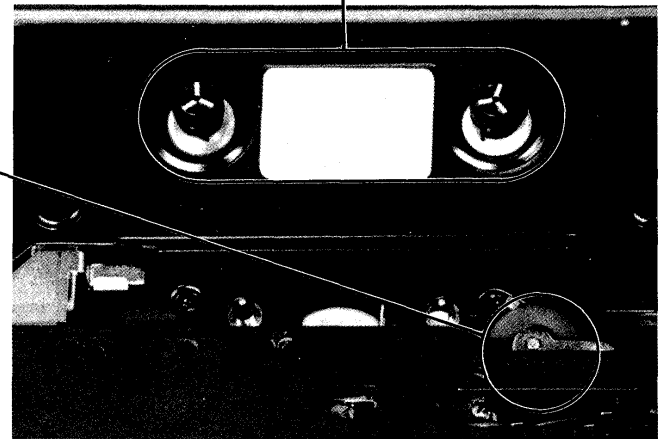

Flywheel (A, B) Thrust Play Adjustment
— Playback Mode —

dc ammeter
6V dc
A
set
terminals of the battery case

1. Turn the thrust screw counterclockwise until the screw tip leaves from the flywheel shaft.
2. Gradually turn the thrust screw clockwise to the position where the motor current suddenly increases.
3. Then, turn the thrust screw counterclockwise about ¼ turn from the position obtained in step 2.

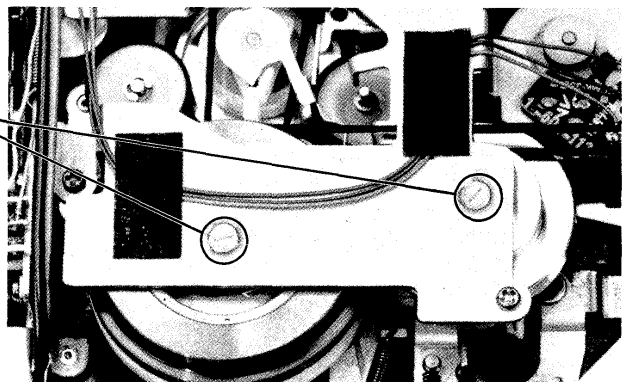

Pause Timing Adjustment

– Playback Mode –

When PAUSE is locked:

The clearance between the pinch roller and capstan should be 0.5 – 1 mm just when the pinch roller is detached from the capstan and the take-up reel spindle stops rotating.

When PAUSE is released:

The pinch roller should start rotating after the take-up reel spindle starts rotating.
The clearance shown below should be obtained.

Procedure:

Change the position of the pinch release plate ass'y.

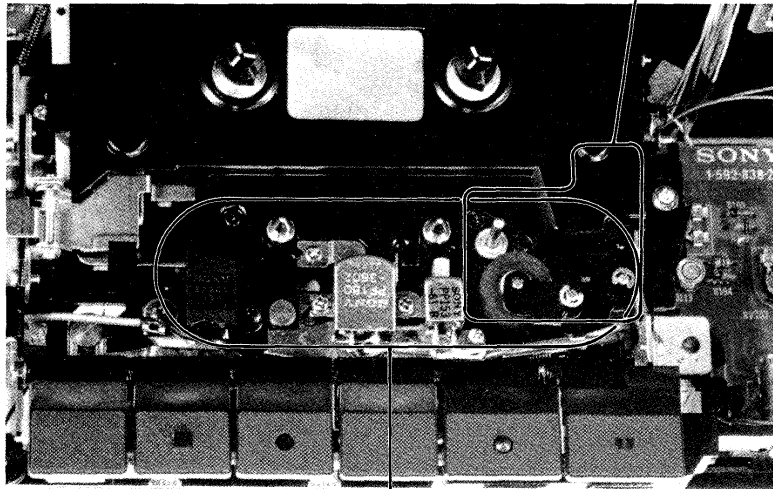
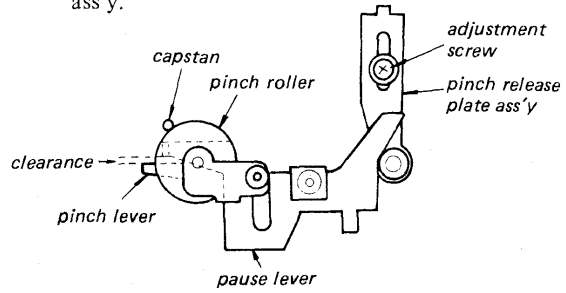

TAPE PATH ADJUSTMENT

1. Use mirror cassette (CQ-009C).
2. In playback mode and viewing from the front, adjust the head heights to eliminate tape curl and tape twist at portions of arrows.

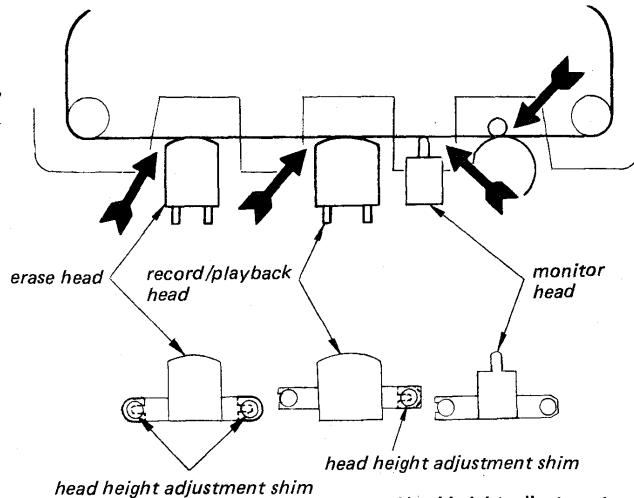

Head height adjustment shim

Part No.	t
3-513-237-01	0.1
3-513-237-11	0.2

3.2. ELECTRICAL ADJUSTMENTS

Note: The adjustment should be performed in the order given in this service manual.

• Standard Record:

Deliver the standard input signal level to the input jack and set the REC/PB VOLUME/VOR SENS control to obtain the standard output signal level.

Standard Input Level

	MIC ①
source impedance	600 Ω
input level	0.77 mV (-60 dB)
input frequency	333 Hz

Standard Output level

	EARPHONE
load impedance	10 kΩ
output level	0.62 (-2 dB)

Tape Speed Adjustment

Setting:

REC/PB VOLUME/
VOR SENS control mechanical mid
TONE control mechanical mid
SPEED control NORM
(mechanical mid)

Procedure:

Mode: playback

test tape
WS-48A
(3 kHz, 0 dB)

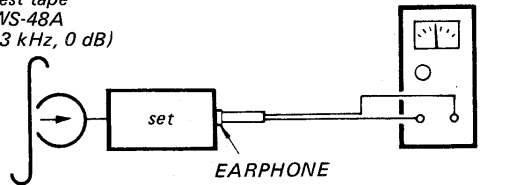

Specification:

Speed checker	Digital frequency counter
-1.5 to +2 %	2,955 - 3,060 Hz

Frequency difference between the beginning and the end of the tape should be within 1 % (30 Hz).

Adjustment Location:

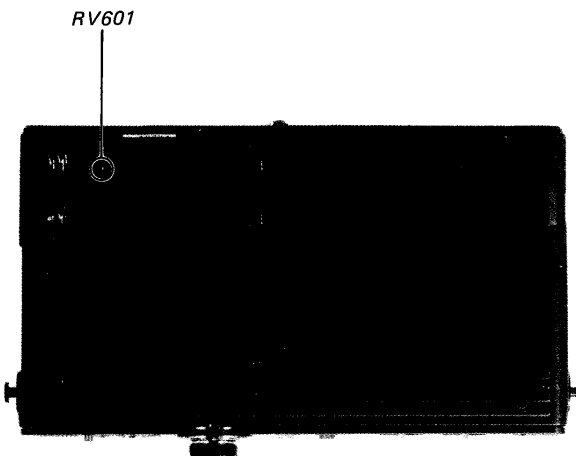

Record/playback Head Azimuth Adjustment

Setting:

REC/PB VOLUME/
VOR SEN control mechanical mid
TONE control mechanical mid
SPEED control NORM
(mechanical mid)

Procedure:

1. Mode: playback

test tape
P-4-A063
(6.3 kHz, -10 dB)

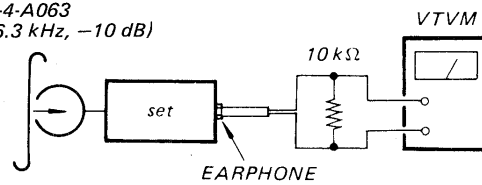

2. Turn the adjustment screw for maximum VTVM reading.

Note: Several peaks may appear, take the maximum.

Adjustment Location:

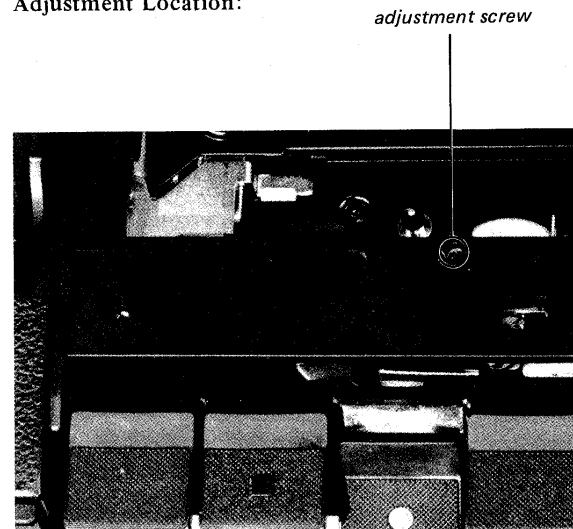

Monitor Head Azimuth Adjustment and Lateral Alignment

Setting:

REC MODE switch MANUAL
 TONE control mechanical mid
 SPEED control NORM
 (mechanical mid)

Procedure:

1. Mode: record

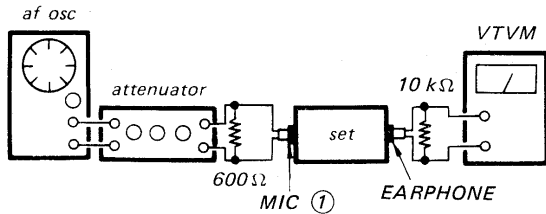

2. MONITOR switch: SOURCE
 REC/PB VOLUME/VOR SENS control: standard record (See page 15)
3. MONITOR switch: TAPE
 MIC ① jack input level: 6.3 kHz, 0.25 mV (-70 dB)
4. Turn the lateral alignment screw and azimuth adjustment screw for maximum VTVM reading.

Adjustment Location:

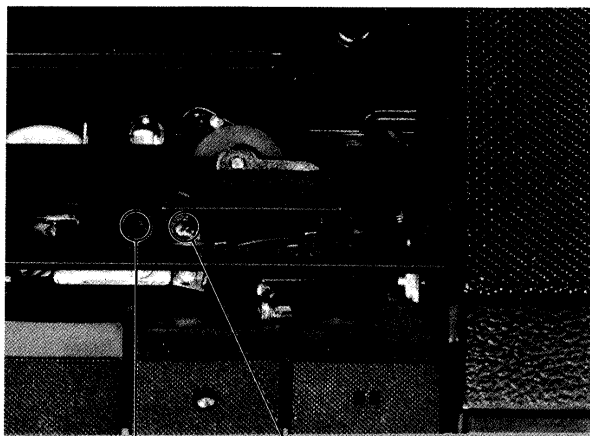

lateral alignment screw *azimuth adjustment screw*

Monitor Level Adjustment

Setting:

REC MODE switch MANUAL
 TONE control mechanical mid
 SPEED control NORM
 (mechanical mid)

Procedure:

1. Mode: record

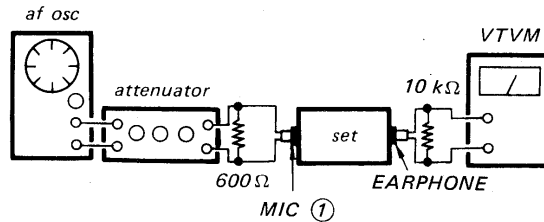

2. MONITOR switch: SOURCE
 REC/PB VOLUME/VOR SENS control: standard record (See page 15)
3. MONITOR switch: TAPE
4. Adjust RV103 for 0.62 V (-2 dB) VTVM reading.

Adjustment Location: Audio board

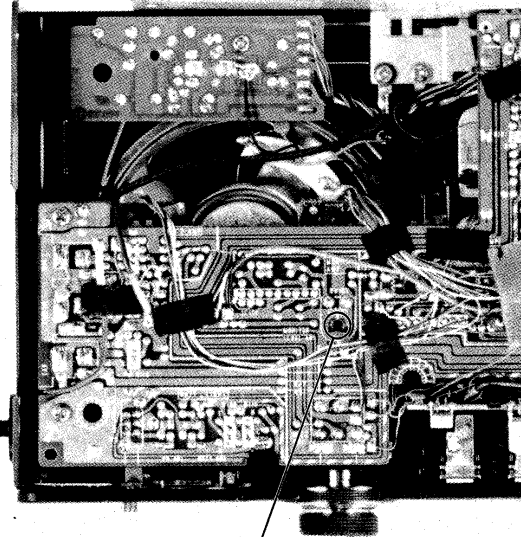

RV103

Record Bias Adjustment

Setting:

- REC MODE switch MANUAL
- MONITOR switch SOURCE
- TONE control mechanical mid
- SPEED control NORM
(mechanical mid)
- REC/PB VOLUME control . . . standard record
(see page 15)

Procedure:

1. Mode: record

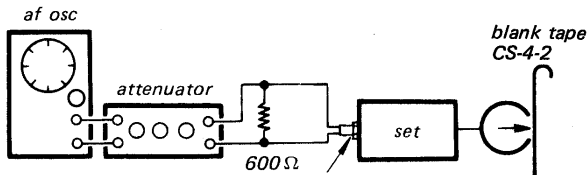

2. Mode: playback

- MIC ①
- 1) 333 Hz } 0.25 mV
- 2) 6.3 kHz } (-70 dB)

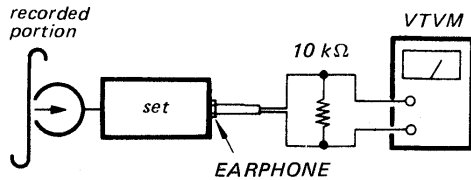

3. Playback 333 Hz, adjust REC/PB VOLUME/VOR SENS control for 0.25 V (-10 dB) VTVM reading.
4. Playback 6.3 kHz: 0.19 – 0.31 V (-10 dB ± 2 dB)
5. If necessary, change the pattern connections and repeat the steps given above.

Adjustment Location: Audio board

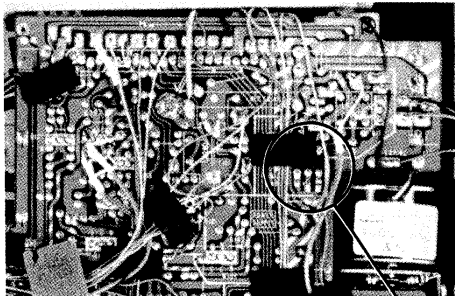

Pattern connection	6.3 kHz VTVM reading
parallel	up
①	↑
②	↕
③	down

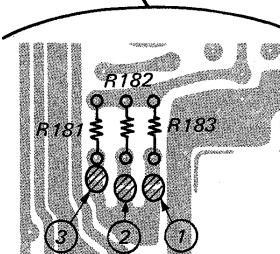

Level Meter Adjustment

Setting:

- Power Supply Voltage MANUAL
- MONITOR switch SOURCE
- TONE control mechanical mid
- SPEED control NORM
(mechanical mid)

Procedure:

1. Mode: record

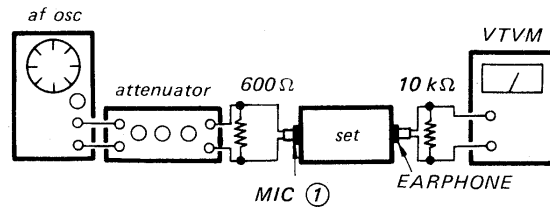

2. REC/PB VOLUME/VOR SENS control: standard record (See page 15)
3. Adjust the pattern connection for "0 dB ± 1 dB" indication on the LEVEL/BATT meter.

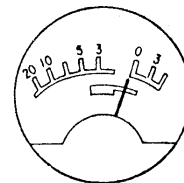

LEVEL/BATT meter

Adjustment Location: Audio board

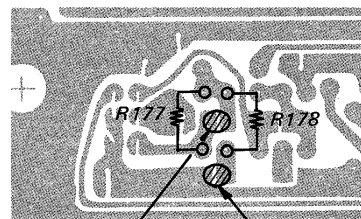
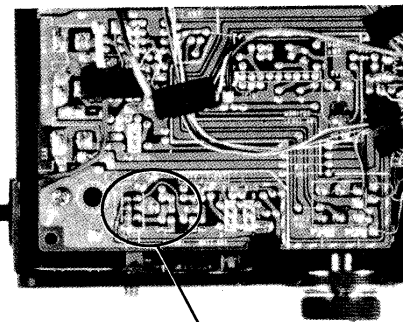

The pointer goes to the right.

The pointer goes to the left.

Battery Indicator Adjustment

Setting:

Power Supply Voltage 4.4 Vdc
 REC/PB VOLUME/
 VOR SENS control minimum
 SPEED control NORM
 (mechanical mid)

Procedure:

1. Mode: playback with no cassette loaded.
2. Push BATT CHECK button, adjust the pattern connection for “-4 to -2 dB” indication on the LEVEL/BATT meter.

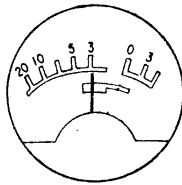

LEVEL/BATT meter

Adjustment Location: Audio board

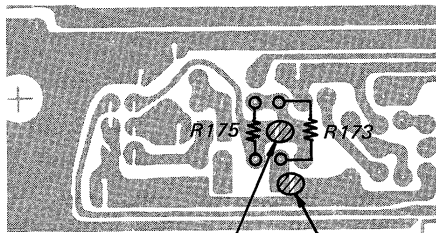
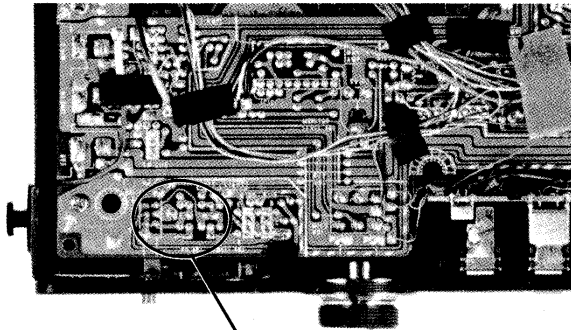

The pointer goes to the right.

The pointer goes to the left.

Pre-End Alarm Adjustment

Procedure:

1. Mode: record

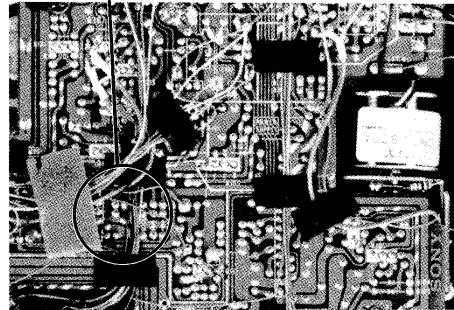
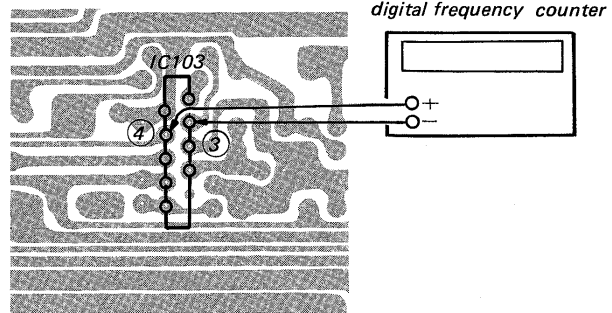

2. Adjust RV104 for 900 Hz reading on the frequency counter.
3. If necessary, solder the portion shown below and repeat the step 2.

Adjustment Location: Audio board

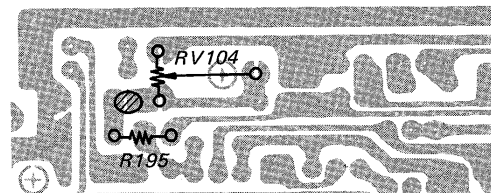
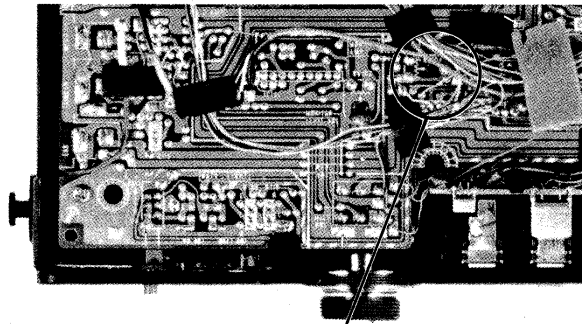

Erase Head Current Adjustment

Setting:

REC MODE SWITCH MANUAL

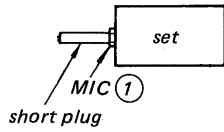

1. Remove earth-side lead of erase head and connect VTVM as illustrated below.
 2. When inserting shorting plug into MIC ① jack and pushing REC button, adjust T701 for maximum VTVM reading.
- Specification: more than 49 mV

Adjustment Location: Bias board

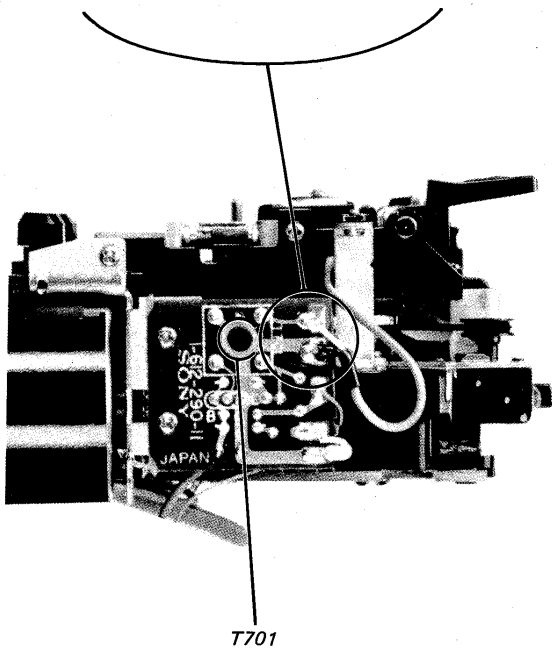
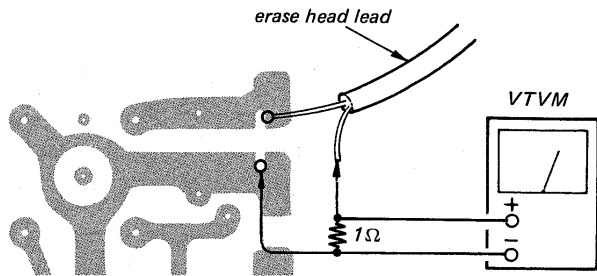

BBD Distortion Adjustment

Setting:

Power Supply Voltage 4.4 V
 REC MODE VOR
 REC/PB VOLUME/VOR SENS MAX

Procedure:

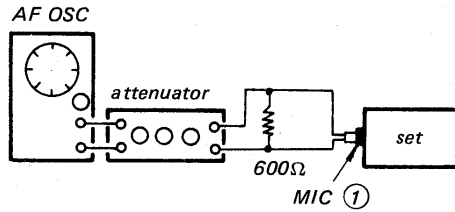

1. Connect distortion meter to the position as illustrated below.
2. Apply 1 kHz, -60 dB signal to MIC ① jack and push REC button. Adjust the pattern connection for less than 3% distortion meter reading.

Adjustment Location: Control board

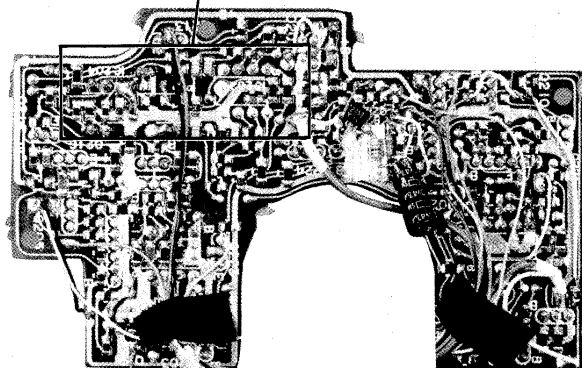
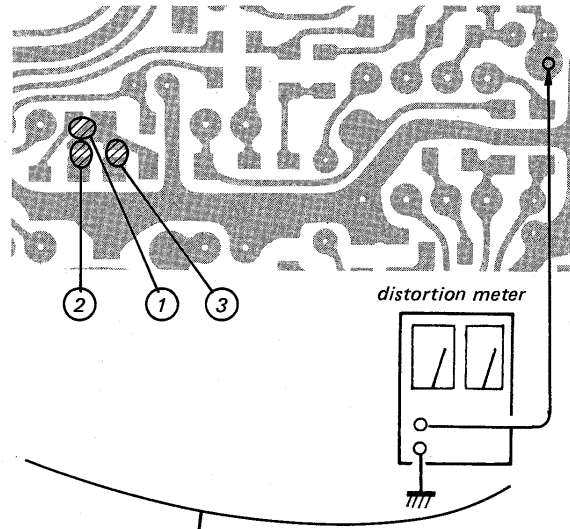

Lowpass Filter Output Adjustment

Setting:

REC MODE VOR
 REC/PB VOLUME/VOR SENS MAX

Procedure:

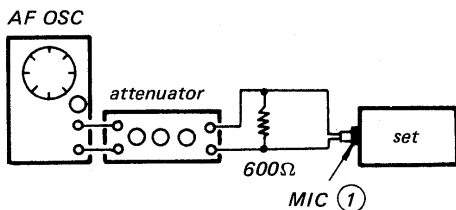

1. Connect VTVM to the position as illustrated below.
2. Apply 1 kHz, -60 dB signal to MIC ① jack and push REC button. Adjust the pattern connection for -56 dB ± 2 dB VTVM reading.

Adjustment Location: Control board

Pattern connection	VTVM reading
parallel	down
①	↑
②	↕
③	↓
	up

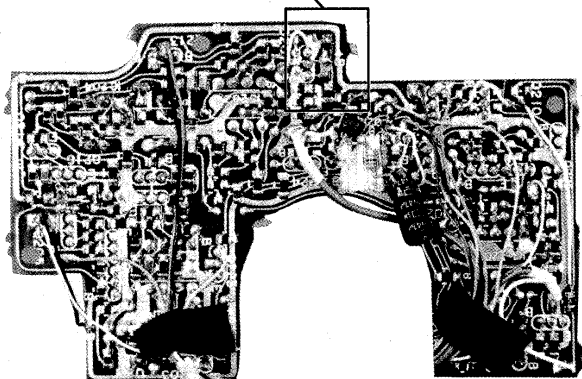
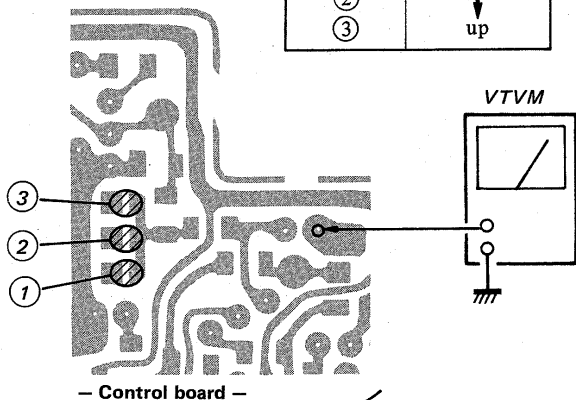

4.1. MOUNTING DIAGRAM

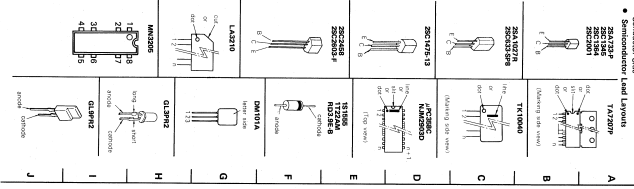

SECTION 4
DIAGRAMS

TCM-5000EV TCM-5000EV

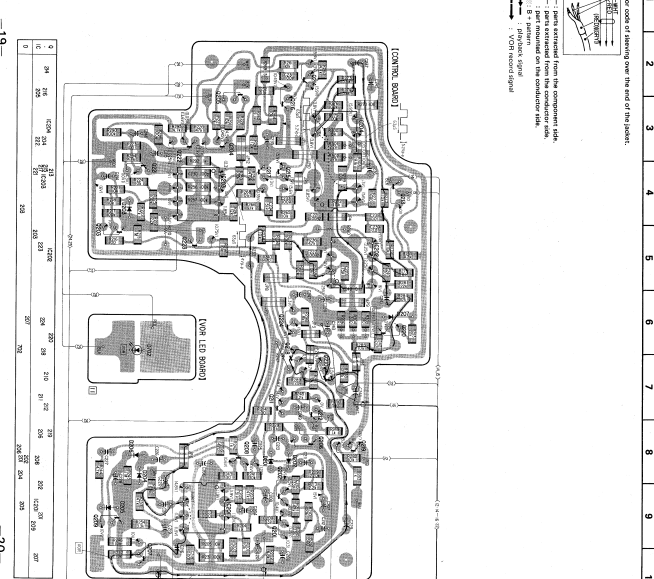

TCM-5000EV TCM-5000EV

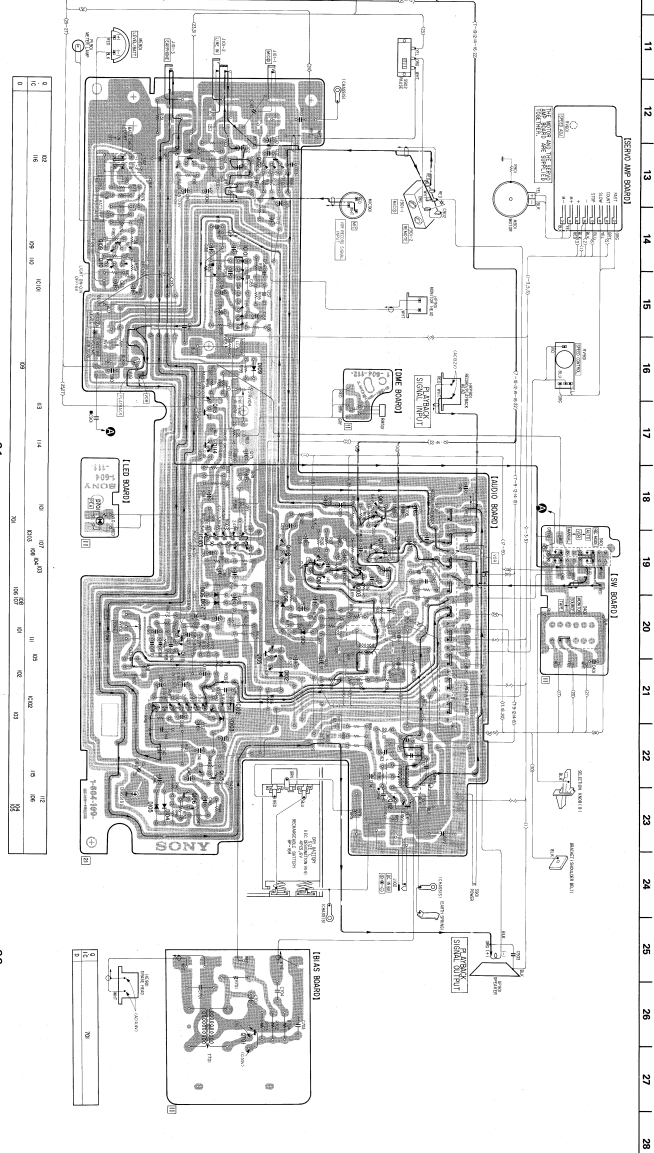

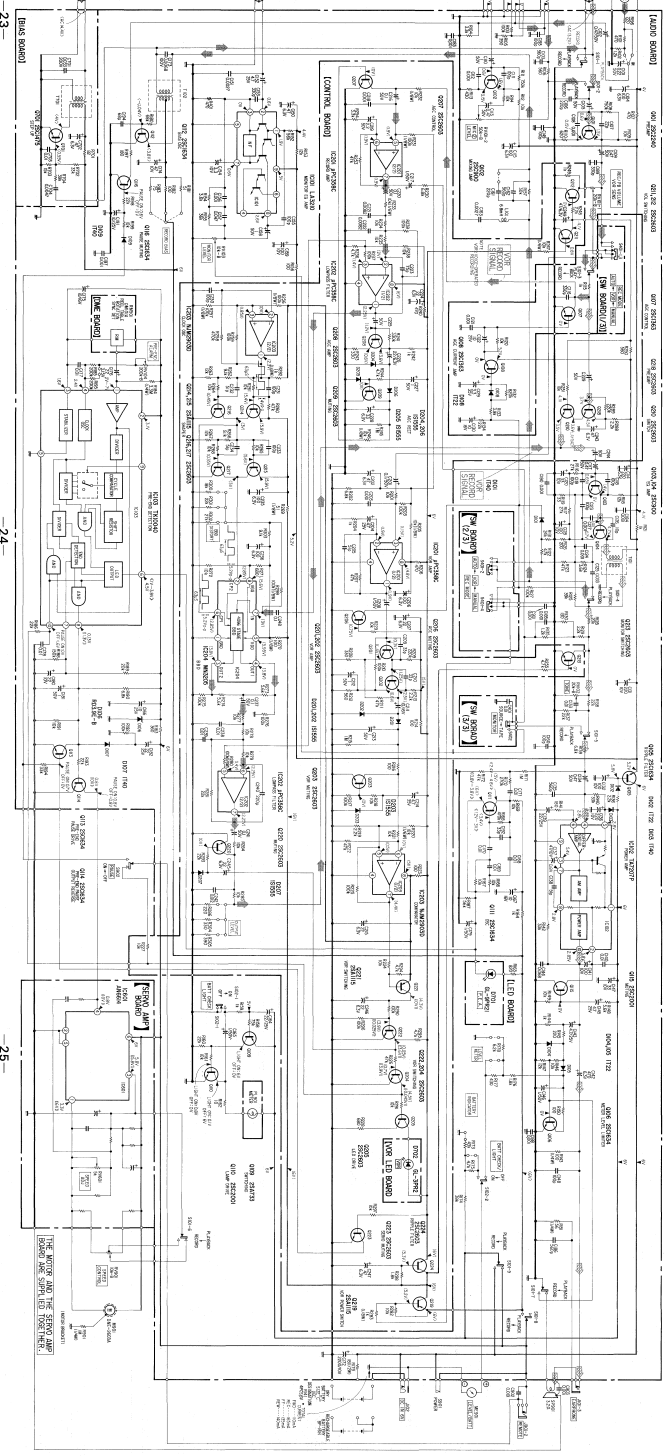

-23-

-24-

-25-

-26-

Part No.	Series	Position
51011-1-5	REORDERLYA/RACK	PC A/V RACK
51021-1-2	VARIABLET/CHECK	V.U
51031-1-4	REORDERLYA/RACK	REORDERLYA/RACK
51041-1-4	POWER	POWER
51051-1-4	VIDEO	VIDEO
51061-1-4	AUDIO	AUDIO

Note: * Voltage are measured with a VOM (50K/50V).

- Note:
- All capacitors are in μ unless otherwise stated. PFT and 500V or less are not indicated except for electrolytic.
 - All resistors are in Ω unless specified for other units.
 - Resistor values are given in the units indicated by the multiplier (K, M, R, etc.).
 - R, K, M, and G indicate ohms, kilohms, megohms, and gigohms, respectively.
 - Values in parentheses are for reference only.
 - Inductors are shown under "reference conditions" with a reference voltage in parentheses.
 - Inductance values are in millihenries unless otherwise specified.
 - Inductors are shown under "reference conditions" with a reference voltage in parentheses.
 - Inductance values are in millihenries unless otherwise specified.

TCM-5000EV TCM-5000EV

SECTION 5
EXPLODED VIEWS AND PARTS LIST

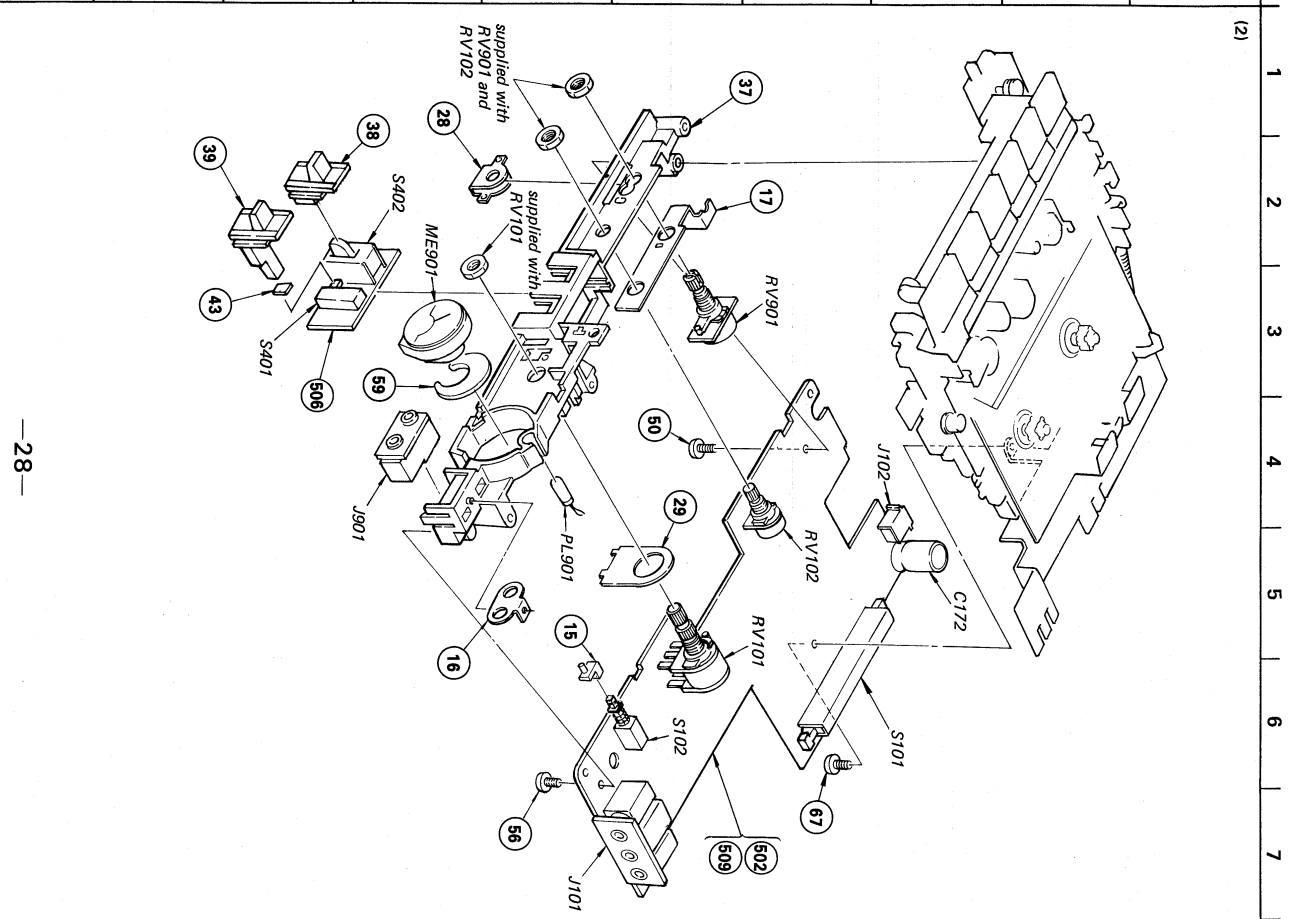
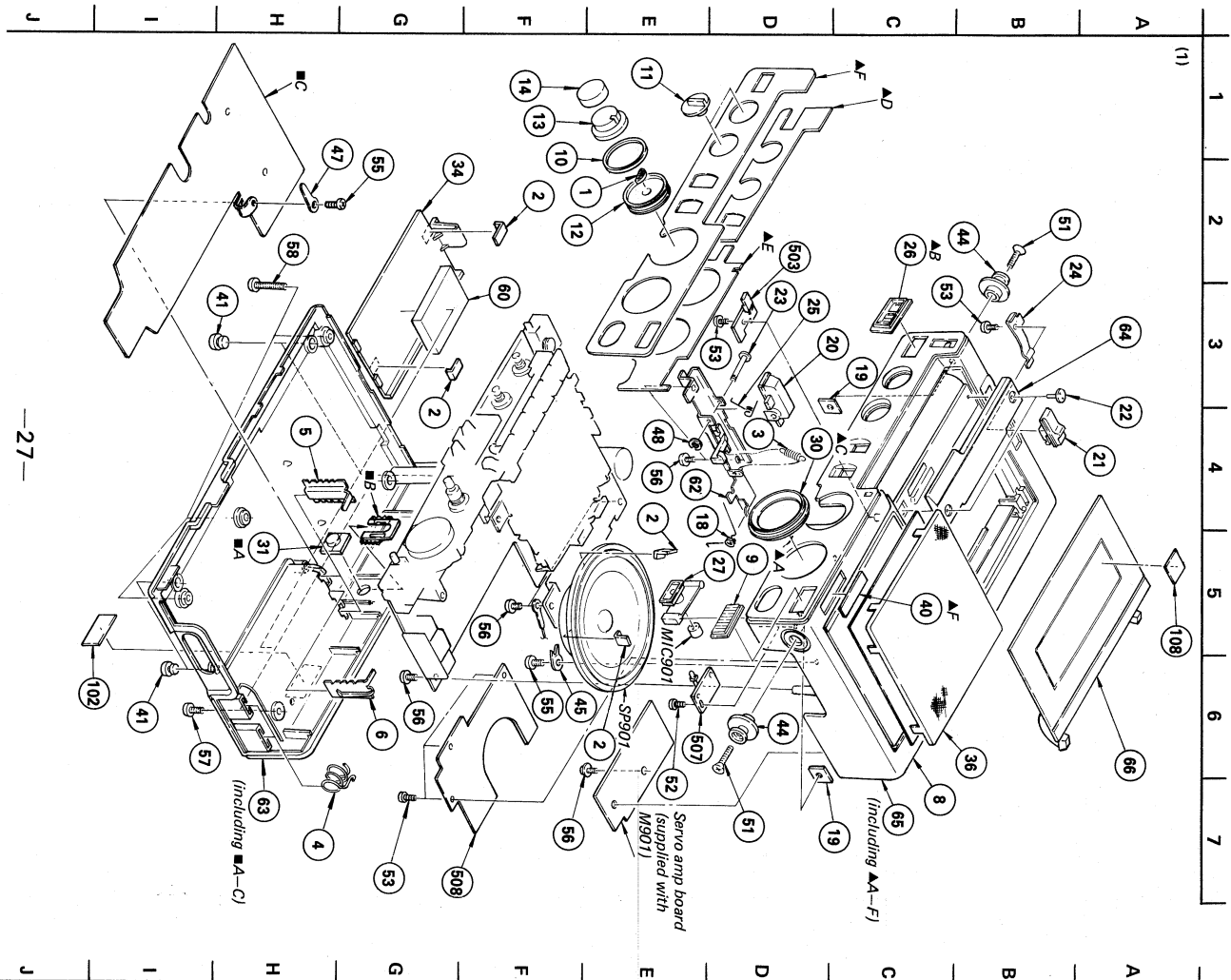

TCM-5000EV TCM-5000EV

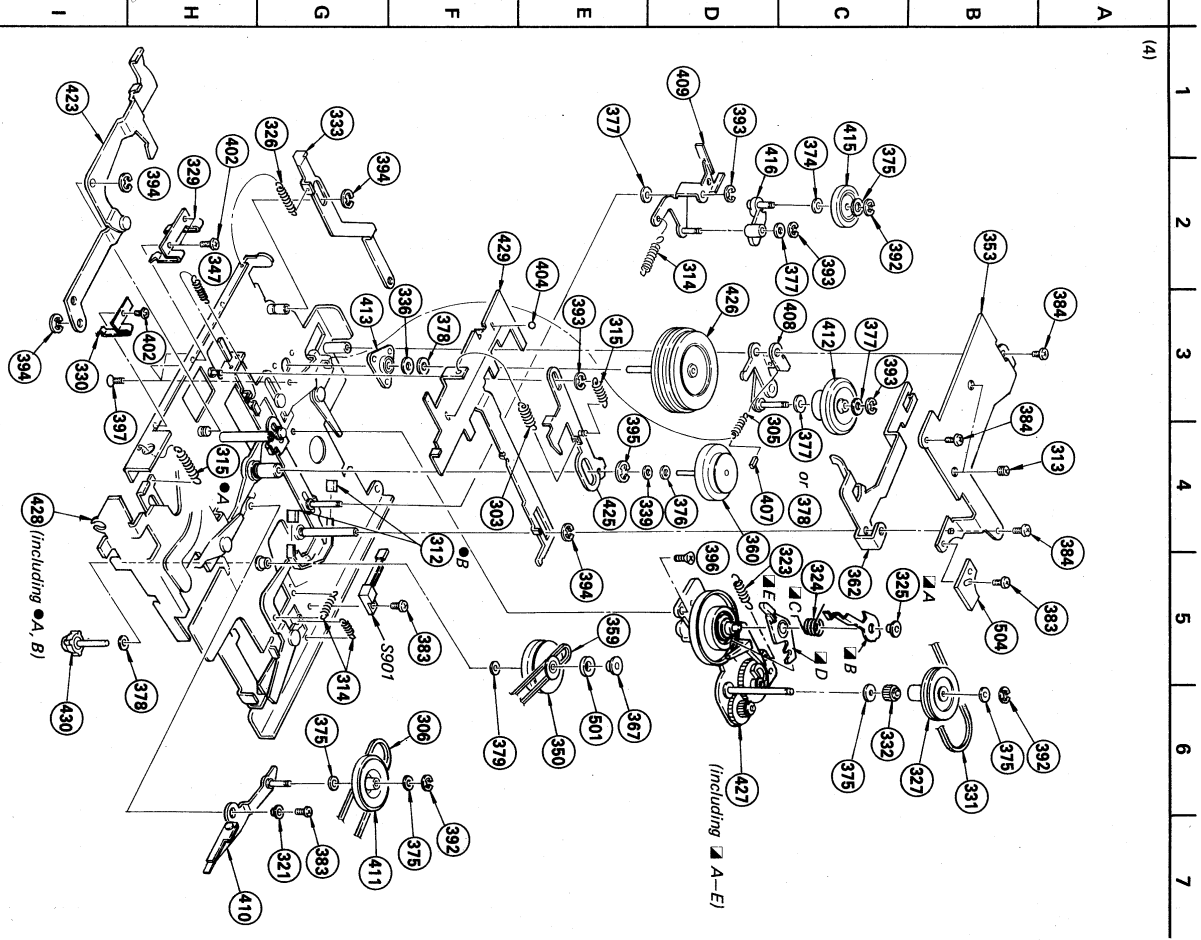
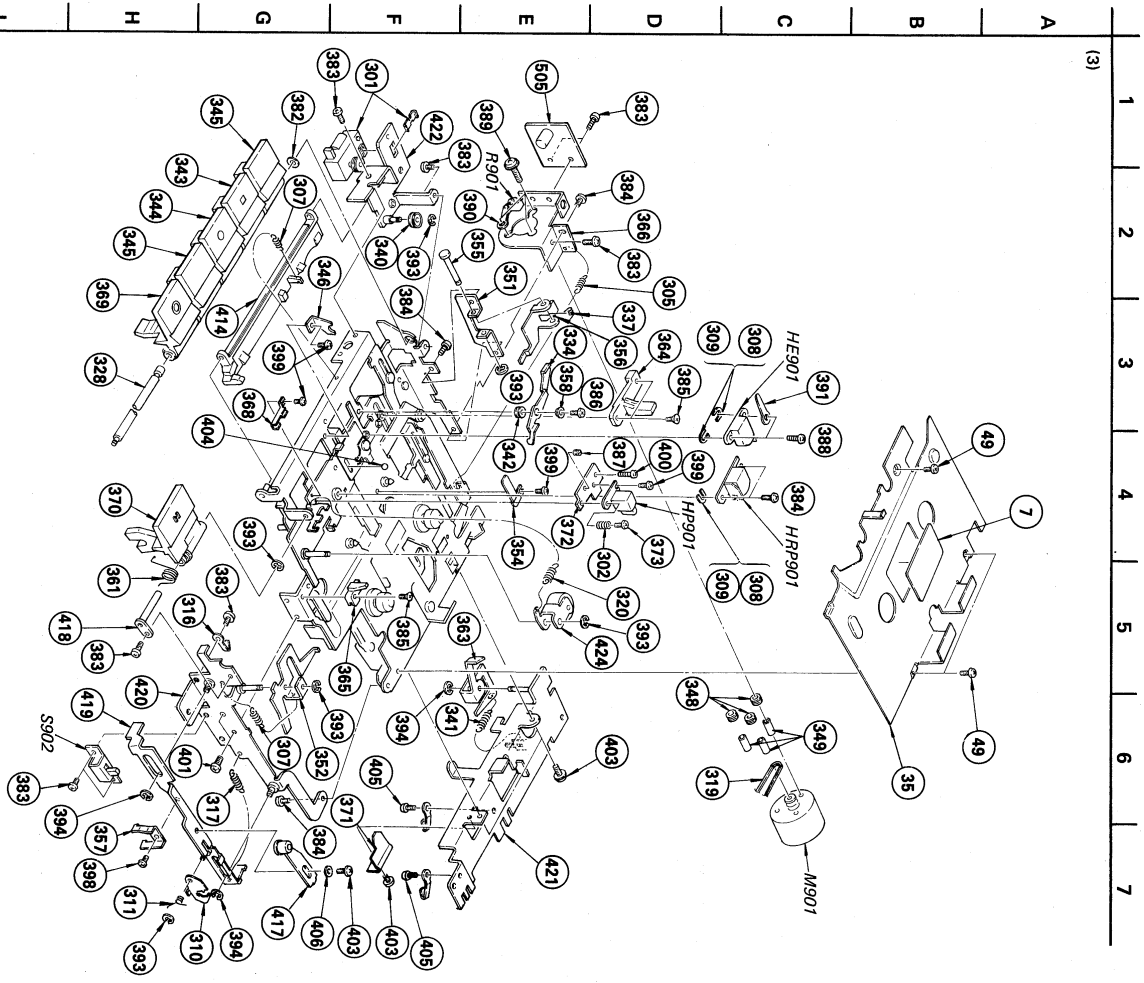

GENERAL SECTION

No.	Part No.	Description
1	0-051-221-00	PAD, KNOB
2	3-485-343-01	CUSHION, CABINET UPPER 10X7X0.5
3	3-489-310-XX	SPRING, TENSION
4	3-501-055-XX	SPRING
5	3-501-056-00	TERMINAL, POSITIVE
6	3-536-912-00	CONTACT
7	3-556-221-00	PLATE, ORNAMENTAL
8	3-576-609-00	CUSHION, SPEAKER
9	♣;3-576-610-00	GRILLE, MICROPHONE
10	3-576-611-00	RING, RUBBER
11	3-576-612-00	KNOB
12	3-576-614-00	KNOB, REC CONTROL
13	3-576-615-00	KNOB, PB
14	3-576-616-00	CAP, PB RUBBER
15	3-576-617-00	BUTTON, BATT CHECK
16	3-576-618-00	PANEL, REMOTE MICROPHONE
17	♣;3-576-620-00	PLATE, GROUND
18	3-576-621-00	SPRING
19	♣;3-576-622-00	BRACKET (SHOULDER BELT)
20	3-576-623-00	BUTTON, EJECT
21	3-576-624-00	KNOB, LOCK
22	3-576-625-00	SCREW, PIN-FACE
23	♣;3-576-626-00	SHAFT, EJECT BUTTON
24	3-576-630-00	SPRING
25	3-576-631-00	SPRING
26	♣;3-576-632-00	PANEL, COUNTER
27	3-576-633-00	HOLDER, MICROPHONE
28	♣;3-576-634-00	BRACKET, ADJUSTMENT
29	♣;3-576-635-00	PLATE, GROUND, CONTROL
30	♣;3-576-636-00	RING, METER
31	3-576-637-00	SCREW, CARRYING CASE
32	
33	
34	3-576-641-00	LID, BATTERY CASE
35	♣;3-576-642-00	PLATE, BLIND
36	3-576-644-00	GRILLE, SPEAKER
37	3-576-649-00	CHASSIS, MOLD
38	3-577-511-01	KNOB (A), SELECTION
39	3-577-512-01	KNOB (B), SELECTION
40	3-644-001-00	EMBLEM, SONY
41	3-701-188-XX	FOOT, RUBBER
42	
43	3-831-441-XX	CUSHION
44	3-888-404-00	SHAFT, BELT
45	♣;4-014-646-00	RETAINER, SPEAKER

NOTE:

- The mechanical parts with no reference number in the exploded views are not supplied.
- Items marked "♣" are not stocked since they are seldom required for routine service. Some delay should be anticipated when ordering these items.
- Due to standardization, parts with part numbers (Δ-ΔΔΔ-ΔΔΔ-XX or Δ-ΔΔΔΔ-ΔΔΔ-X) may be different from those used in the set.
- If there are two or more same circuits in a set such as a stereophonic machine, only typical circuit parts may be indicated and capacitors and resistors in other same circuits may be omitted.

GENERAL SECTION

No.	Part No.	Description
46	7-621-255-15	SCREW +P 2X3
47	7-623-508-01	LUG, 3
48	7-624-104-04	STOP RING 2.0, TYPE -E
49	7-627-553-28	SCREW, PRECISION +P 2X2.5
50	7-682-553-04	SCREW +P 3X20
51	7-682-351-09	SCREW +RK 3X14
52	7-685-104-14	SCREW +P 2X6 TYPE2 SLIT
53	7-685-132-21	SCREW +P 2.6X5 TYPE2 SLIT
54	7-685-133-14	SCREW +P 2.6X6 TYPE2 SLIT
55	7-685-145-14	SCREW +P 3X6 TYPE2 SLIT
56	7-685-146-14	SCREW +P 3X8 TYPE2 SLIT
57	7-685-147-29	SCREW +P 3X10 TYPE2 SLIT
58	7-685-155-29	SCREW +P 3X40 TYPE2 SLIT
59	♣;3-576-601-01	CUSHION, METER
60	9-911-815-02	CUSHION
61	9-911-815-03	CUSHION (POINTER)
62	X-3576-602-0	CHASSIS ASSY, EJECT
63	X-3576-626-1	CABINET (LOWER) ASSY
64	X-3576-627-1	PANEL ASSY, HEAD
65	X-3576-628-1	CABINET (UPPER) ASSY
66	X-3576-630-1	LID ASSY, CASSETTE
67	7-682-145-01	+P 3X4

ACCESSORY & PACKING MATERIAL

No.	Part No.	Description
101	3-577-524-01	INDIVIDUAL CARTON
102	3-701-999-00	(US).....LABEL, SERIAL NUMBER
102	3-527-213-00	(Canadian,AEP,UK,E)...LABEL, SERIAL NUMBER
103	1-504-059-11	MAGNETIC EARPHONE(ME-20H)
104	1-528-026-00	BATTERY, NEW SUPER (SUM-2)(NS)
105	1-551-841-00	CORD, CONNECTION (RK-69A)
106	3-576-699-00	CUSHION
107	3-577-502-00	BOX, ACCESSORY
108	3-703-707-01	STICKER, SONY SYMBOL (21)
109	3-577-508-00	STOPPER
110	3-701-625-00	BAG, POLYETHYLENE
111	3-703-468-11	BAG, POLYETHYLENE
112	3-773-811-11	(AEP,UK,E).....MANUAL, INSTRUCTION
112	3-773-811-21	(US,Canadian)..MANUAL, INSTRUCTION
112	3-773-811-31	(Canadian).....MANUAL, INSTRUCTION
112	3-773-811-41	(AEP).....MANUAL, INSTRUCTION
113	3-793-828-11	QUESTIONNAIRE
114	X-2290-801-0	CASE ASSY, CARRYING
115	X-3576-625-1	BELT ASSY, CARRYING

CAPACITORS:

MF:μF, PF:μμF.

RESISTORS

- All resistors are in ohms.
- F : nonflammable

COILS

MMH : mH, UH : μH

SEMICONDUCTORS

In each case, U : μ, for example:
 UA....: μA...., UPA....: μPA...., UPC....: μPC,
 UPD....: μPD....

MECHANISM SECTION

No.	Part No.	Description
301	1-548-548-00	COUNTER, TAPE (SUPER SMALL)
302	3-318-106-01	SPRING (H), COMPRESSION
303	3-437-026-00	SPRING, TENSION
304	
305	3-489-310-XX	SPRING, TENSION
306	3-507-115-00	BELT, (A)
307	3-509-127-00	SPRING, TENSION
308	3-513-237-01	PLATE
309	3-513-237-11	PLATE
310	3-515-074-00	PLATE, LOCK
311	3-515-076-00	SPRING
312	3-527-028-00	RUBBER, BRAKE
313	3-527-140-00	SCREW, THRUST
314	3-527-188-00	SPRING, TENSION
315	3-527-193-00	SPRING, TENSION
316	3-528-086-00	RETAINER, CORD
317	3-530-279-00	SPRING, TENSION
318	
319	3-538-931-00	BELT, DRIVE
320	3-539-227-00	SPRING, TENSION
321	3-545-508-00	SPACER
322	
323	3-545-542-00	SPRING, TENSION
324	3-545-550-00	SPRING, COMPRESSION
325	3-545-551-00	RETAINER (D), SPRING
326	3-545-588-00	SPRING, TENSION
327	3-545-592-00	PULLEY, MIDWAY
328	♣;3-545-593-00	SHAFT, BUTTON
329	3-545-597-00	SPRING
330	3-545-598-00	SPRING
331	3-545-601-XX	BELT, MIDWAY PULLEY
332	3-545-606-00	GEAR
333	♣;3-545-608-00	LEVER (B), SHUT-OFF
334	3-545-609-11	LEVER (A), REVIEW
335	
336	3-545-715-00	WASHER
337	3-545-787-00	SPRING
338	
339	3-547-734-00	WASHER
340	3-549-452-00	PULLEY, SHUT-OFF
341	3-554-122-00	SPRING, TENSION
342	3-556-280-00	ROLLER, GUIDE
343	3-557-837-00	BUTTON, STOP
344	3-557-839-00	BUTTON, FWD
345	3-557-840-00	BUTTON, FR

MECHANISM SECTION

No.	Part No.	Description
346	3-557-846-00	HOLDER, BUTTON SHAFT
347	3-559-434-00	SPRING, TENSION
348	3-566-030-00	RUBBER, VIBRATION PROOF
349	3-566-031-00	SPACER
350	3-566-041-00	PULLEY, S REEL TABLE
351	♣;3-576-650-00	BRACKET, EJECT
352	♣;3-576-651-00	LEVER, PAUSE
353	♣;3-576-654-00	RETAINER, THRUST
354	♣;3-576-655-00	RETAINER, CHASSIS, HEAD
355	♣;3-576-656-00	SHAFT, LEVER, EJECT
356	♣;3-576-657-00	BRACKET, EJECT
357	3-576-665-00	SPRING
358	♣;3-576-673-00	SPACER
359	3-576-677-00	BELT
360	3-576-678-00	FLYWHEEL (B)
361	3-576-679-00	SPRING
362	♣;3-576-680-00	LEVER, PREVENTION, SHAFT OFF
363	♣;3-576-681-00	LEVER, SUPPORT, REC
364	3-576-683-00	GUIDE (L), CASSETTE
365	3-576-684-00	GUIDE (R), CASSETTE
366	♣;3-576-685-00	BRACKET, MOTOR
367	3-576-687-00	BUSHING
368	♣;3-576-688-00	RETAINER, LEAD, HEAD
369	3-576-693-00	BUTTON, REC
370	3-576-694-00	BUTTON, PAUSE
371	♣;3-577-503-00	PLATE, SHIELD
372	♣;3-577-516-01	TABLE, MONITOR HEAD
373	3-577-517-01	SCREW (1.7), PRECISION SPECIAL
374	3-701-436-01	WASHER, 1.6
375	3-701-436-11	WASHER, 1.6
376	3-701-436-21	WASHER, POLYETHYLENE
377	3-701-437-01	WASHER
378	3-701-437-11	WASHER
379	3-701-437-21	WASHER
380	3-701-439-01	WASHER
381	3-701-439-11	WASHER
382	3-701-440-21	WASHER, 3.5
383	7-621-255-15	SCREW +P 2X3
384	7-621-255-25	SCREW +P 2X4
385	7-621-555-30	SCREW +K 2X5
386	7-621-555-52	SCREW +K 2X8
387	7-621-710-25	SET-SCREW, SLOT 2X3 CONE POINT
388	7-621-772-20	SCREW +B 2X5
389	7-621-955-45	SCREW, TOTSU PWH 2X6
390	7-623-505-01	LUG, 2

NOTE:

- The mechanical parts with no reference number in the exploded views are not supplied.
- Items marked "♣" are not stocked since they are seldom required for routine service. Some delay should be anticipated when ordering these items.
- Due to standardization, parts with part numbers (Δ-ΔΔΔ-ΔΔΔ-XX or Δ-ΔΔΔΔ-ΔΔΔ-X) may be different from those used in the set.
- If there are two or more same circuits in a set such as a stereophonic machine, only typical circuit parts may be indicated and capacitors and resistors in other same circuits may be omitted.

CAPACITORS:

MF:μF, PF:μμF.

RESISTORS

- All resistors are in ohms.
- F : nonflammable

COILS

• MMH : mH, UH : μH

SEMICONDUCTORS

In each case, U : μ, for example:
 UA....: μA...., UPA....: μPA...., UPC....: μPC,
 UPD....: μPD....

MECHANISM SECTION

No.	Part No.	Description
391	7-623-507-01	LUG, 2.6
392	7-624-101-04	STOP RING 1.2 (E TYPE)
393	7-624-102-04	STOP RING 1.5, TYPE -E
394	7-624-104-04	STOP RING 2.0, TYPE -E
395	7-624-109-04	STOP RING 5.0, TYPE -E
396	7-627-452-17	SCREW, PRECISION +K 2X2
397	7-627-452-28	SCREW, PRECISION +K 2X4
398	7-627-552-27	SCREW, PRECISION +P 1.7X2
399	7-627-553-13	SCREW, PRECISION +P 2X2
400	7-627-553-37	SCREW, PRECISION +P 2X3
401	7-627-554-17	SCREW, PRECISION +P 2X3.5
402	7-627-853-27	PRECISION SCREW +P. 2X3 TYPE 3
403	7-628-253-05	SCREW +PS 2X4
404	7-671-112-01	STEEL, BALL
405	7-682-544-04	SCREW +P 3X3
406	7-688-001-11	W 2, MIDDLE
407	9-911-815-02	CUSHION
408	•;X-3545-511-0	LEVER (C) ASSY, FF
409	•;X-3545-512-0	LEVER (A) ASSY, FWD
410	X-3545-513-0	LEVER (B) ASSY, REW
411	X-3545-514-0	PULLEY ASSY, REW
412	X-3545-515-0	PULLEY ASSY, FF
413	X-3545-516-0	RETAINER ASSY, CAPSTAN SHAFT
414	X-3545-517-0	PLATE ASSY, LOCK
415	X-3545-521-0	PULLEY ASSY, FWD
416	X-3545-533-0	LEVER (B) ASSY, FWD
417	•;X-3556-208-0	PLATE ASSY, RELEASE, PINCH
418	•;X-3556-219-0	SHAFT ASSY, PAUSE
419	X-3576-605-0	SLIDER ASSY, PAUSE
420	X-3576-606-0	CHASSIS ASSY, PAUSE
421	•;X-3576-608-0	BRACKET ASSY, MD
422	•;X-3576-609-0	BRACKET ASSY, COUNTER
423	•;X-3576-610-0	LEVER (A) ASSY, REC
424	X-3576-611-0	PINCH LEVER ASSY
425	•;X-3576-614-0	CHASSIS ASSY, FWD
426	X-3576-615-0	FLYWHEEL ASSY
427	X-3576-617-0	SHUT-OFF COMPLETE ASSY
428	X-3576-618-0	CHASSIS ASSY, MECHANICAL
429	X-3576-624-1	CHASSIS ASSY, HEAD
430	3-577-521-01	SHAFT, REEL

NOTE:

- The mechanical parts with no reference number in the exploded views are not supplied.
- Items marked " • " are not stocked since they are seldom required for routine service. Some delay should be anticipated when ordering these items.
- Due to standardization, parts with part numbers (Δ-ΔΔΔ-ΔΔΔ-XX or Δ-ΔΔΔ-ΔΔΔ-X) may be different from those used in the set.
- If there are two or more same circuits in a set such as a stereophonic machine, only typical circuit parts may be indicated and capacitors and resistors in other same circuits may be omitted.

ELECTRICAL PARTS

Ref.No.	Part No.	Description				
501	1-452-193-00	MAGNET				
502	•;1-604-109-00	PC BOARD, AUDIO				
503	•;1-604-111-00	PC BOARD, LED				
504	•;1-604-112-00	PC BOARD, DME				
505	•;1-612-290-11	PC BOARD, BIAS				
506	•;1-612-291-11	PC BOARD, SW				
507	•;1-612-292-11	PC BOARD, VOR LED				
508	•;A-3015-251-A	PC BOARD ASSY, CONTROL				
509	•;A-3070-122-A	PC BOARD ASSY, AUDIO				
C101	1-124-464-11	ELECT	0.22MF	20%	50V	
C102	1-123-379-00	ELECT	0.47MF	20%	50V	
C103	1-102-115-00	CERAMIC	560PF	10%	50V	
C104	1-123-307-00	ELECT	100MF	20%	6.3V	
C105	1-123-380-00	ELECT	1MF	20%	50V	
C106	1-102-110-00	CERAMIC	220PF	10%	50V	
C107	1-102-959-00	CERAMIC	22PF	5%	50V	
C108	1-102-074-00	CERAMIC	0.001MF	10%	50V	
C109	1-123-379-00	ELECT	0.47MF	20%	50V	
C110	1-123-380-00	ELECT	1MF	20%	50V	
C111	1-102-106-00	CERAMIC	100PF	10%	50V	
C112	1-102-074-00	CERAMIC	0.001MF	10%	50V	
C113	1-123-379-00	ELECT	0.47MF	20%	50V	
C114	1-123-308-00	ELECT	220MF	20%	6.3V	
C115	1-123-307-00	ELECT	100MF	20%	6.3V	
C116	1-102-112-00	CERAMIC	330PF	10%	50V	
C117	1-123-379-00	ELECT	0.47MF	20%	50V	
C118	1-102-106-00	CERAMIC	100PF	10%	50V	
C119	1-102-106-00	CERAMIC	100PF	10%	50V	
C120	1-123-318-00	ELECT	33MF	20%	10V	
C121	1-108-227-00	MYLAR	0.001MF	10%	50V	
C122	1-123-356-00	ELECT	10MF	20%	25V	
C123	1-102-106-00	CERAMIC	100PF	10%	50V	
C124	1-108-227-00	MYLAR	0.001MF	10%	50V	
C125	1-108-591-00	MYLAR	0.033MF	5%	50V	
C126	1-102-947-00	CERAMIC	10PF	5%	50V	
C127	1-102-074-00	CERAMIC	0.001MF	10%	50V	
C128	1-123-307-00	ELECT	100MF	20%	10V	
C129	1-123-613-00	ELECT	3.3MF	20%	35V	
C130	1-123-617-00	ELECT	10MF	20%	16V	
C131	1-123-308-00	ELECT	220MF	20%	10V	
C132	1-123-307-00	ELECT	100MF	20%	10V	
C133	1-108-579-00	MYLAR	0.01MF	5%	50V	
C134	1-123-379-00	ELECT	0.47MF	20%	50V	
C135	1-102-115-00	CERAMIC	560PF	10%	50V	
C136	1-123-308-00	ELECT	220MF	20%	10V	

CAPACITORS:

MF:μF, PF:μμF.

RESISTORS

- All resistors are in ohms.
- F : nonflammable

COILS

• MMH : mH, UH : μH

SEMICONDUCTORS

In each case, U : μ, for example:
 UA... : μA..., UPA... : μPA..., UPC... : μPC,
 UPD... : μPD...

ELECTRICAL PARTS

Ref.No.	Part No.	Description			
C137	1-123-306-00	ELECT	47MF	20%	10V
C138	1-101-882-00	CERAMIC	51PF	5%	50V
C139	1-123-330-00	ELECT	22MF	20%	25V
C140	1-108-239-00	MYLAR	0.01MF	10%	50V
C141	1-123-307-00	ELECT	100MF	20%	10V
C142	1-123-298-00	ELECT	470MF	20%	6.3V
C143	1-123-369-00	ELECT	4.7MF	20%	25V
C144	1-108-599-00	MYLAR	0.068MF	10%	50V
C145	1-123-369-00	ELECT	4.7MF	20%	25V
C146	1-123-380-00	ELECT	1MF	20%	50V
C147	1-123-318-00	ELECT	33MF	20%	10V
C148	1-102-106-00	CERAMIC	100PF	10%	50V
C149	1-102-106-00	CERAMIC	100PF	10%	50V
C150	1-123-306-00	ELECT	47MF	20%	6.3V
C151	1-108-565-00	MYLAR	0.0027MF	5%	50V
C152	1-123-369-00	ELECT	4.7MF	20%	25V
C153	1-102-112-00	CERAMIC	330PF	10%	50V
C154	1-131-501-00	TANTALUM	3.3MF	10%	10V
C155	1-161-271-00	CERAMIC	100PF	5%	50V
C156	1-102-074-00	CERAMIC	0.001MF	10%	50V
C157	1-108-595-00	MYLAR	0.047MF	5%	50V
C158	1-123-380-00	ELECT	1MF	20%	50V
C159	1-123-307-00	ELECT	100MF	20%	10V
C160	1-161-271-00	CERAMIC	100PF	5%	50V
C161	1-102-110-00	CERAMIC	220PF	10%	50V
C162	1-102-115-00	CERAMIC	560PF	10%	50V
C163	1-108-565-00	MYLAR	0.0027MF	5%	50V
C164	1-123-330-00	ELECT	22MF	20%	25V
C165	1-123-380-00	ELECT	1MF	20%	50V
C166	1-123-356-00	ELECT	10MF	20%	25V
C167	1-123-617-00	ELECT	10MF	20%	16V
C168	1-161-013-00	CERAMIC	0.01MF	10%	25V
C169	1-161-013-00	CERAMIC	0.01MF	10%	25V
C170	1-161-013-00	CERAMIC	0.01MF	10%	25V
C171	1-161-013-00	CERAMIC	0.01MF	10%	25V
C172	1-123-325-00	ELECT	2200MF	20%	10V
C173	1-106-192-00	MYLAR	0.0068MF	5%	100V
C174	1-123-306-00	ELECT	47MF	20%	10V
C175	1-123-617-00	ELECT	10MF	20%	16V
C176	1-131-391-00	TANTALUM	22MF	20%	3.15V
C177	1-161-013-00	CERAMIC	0.01MF	10%	25V
C178	1-161-013-00	CERAMIC	0.01MF	10%	25V
C179	1-123-611-00	ELECT	1MF	20%	50V
C180	1-123-644-00	ELECT	22MF	20%	10V
C181	1-123-611-00	ELECT	1MF	20%	50V

ELECTRICAL PARTS

Ref.No.	Part No.	Description			
C182	1-123-330-00	ELECT	22MF	20%	25V
C183	1-102-074-00	CERAMIC	0.001MF	10%	50V
C184	1-161-323-00	CERAMIC	0.001MF	10%	50V
C185	1-102-074-00	CERAMIC	0.001MF	10%	50V
C186	1-102-115-00	CERAMIC	560PF	10%	50V
C187	1-102-074-00	CERAMIC	0.001MF	10%	50V
C188	1-102-074-00	CERAMIC	0.001MF	10%	50V
C189	1-102-112-00	CERAMIC	330PF	10%	50V
C190	1-102-074-00	CERAMIC	0.001MF	10%	50V
C191	1-123-356-00	ELECT	10MF	20%	25V
C192	1-102-963-00	CERAMIC	33PF	5%	50V
C193	1-102-106-00	CERAMIC	100PF	10%	50V
C194	1-101-888-00	CERAMIC	68PF	5%	50V
C201	1-123-607-00	ELECT	0.1MF	20%	50V
C202	1-123-647-00	ELECT	47MF	20%	6.3V
C203	1-163-141-00	CERAMIC CHIP	0.001MF	10%	50V
C204	1-123-616-00	ELECT	4.7MF	20%	25V
C205	1-163-110-00	CERAMIC CHIP	51PF	10%	50V
C206	1-123-661-00	ELECT	100MF	20%	6.3V
C207	1-123-618-00	ELECT	22MF	20%	6.3V
C208	1-123-611-00	ELECT	1MF	20%	50V
C209	1-163-105-00	CERAMIC CHIP	33PF	10%	50V
C210	1-163-105-00	CERAMIC CHIP	33PF	10%	50V
C211	1-123-617-00	ELECT	10MF	20%	16V
C212	1-123-611-00	ELECT	1MF	20%	50V
C213	1-123-611-00	ELECT	1MF	20%	50V
C214	1-123-615-00	ELECT	4.7MF	20%	35V
C215	1-123-618-00	ELECT	22MF	20%	6.3V
C216	1-123-607-00	ELECT	0.1MF	20%	50V
C217	1-123-611-00	ELECT	1MF	20%	50V
C218	1-163-141-00	CERAMIC CHIP	0.001MF	10%	50V
C219	1-123-612-00	ELECT	2.2MF	20%	50V
C220	1-123-607-00	ELECT	0.1MF	20%	50V
C221	1-163-020-00	CERAMIC CHIP	0.0082MF	10%	50V
C222	1-163-020-00	CERAMIC CHIP	0.0082MF	10%	50V
C223	1-163-114-00	CERAMIC CHIP	75PF	10%	50V
C224	1-123-618-00	ELECT	22MF	20%	6.3V
C225	1-123-611-00	ELECT	1MF	20%	50V
C226	1-123-618-00	ELECT	22MF	20%	6.3V
C227	1-123-611-00	ELECT	1MF	20%	50V
C228	1-123-646-00	ELECT	33MF	20%	6.3V
C229	1-123-611-00	ELECT	1MF	20%	50V
C230	1-163-181-00	CERAMIC CHIP	100PF	5%	50V
C231	1-163-117-00	CERAMIC CHIP	100PF	10%	50V
C232	1-163-110-00	CERAMIC CHIP	51PF	10%	50V

NOTE:

- The mechanical parts with no reference number in the exploded views are not supplied.
- Items marked "●" are not stocked since they are seldom required for routine service. Some delay should be anticipated when ordering these items.
- Due to standardization, parts with part numbers (Δ-ΔΔΔ-ΔΔΔ-XX or Δ-ΔΔΔΔ-ΔΔΔ-X) may be different from those used in the set.
- If there are two or more same circuits in a set such as a stereophonic machine, only typical circuit parts may be indicated and capacitors and resistors in other same circuits may be omitted.

CAPACITORS:

MF:μF, PF:μμF.

RESISTORS

All resistors are in ohms.

F : nonflammable

COILS

MMH : mH, UH : μH

SEMICONDUCTORS

In each case, U : μ, for example:

UA...: μA..., UPA...: μPA..., UPC...: μPC,

UPD...: μPD...

ELECTRICAL PARTS

Ref.No.	Part No.	Description			
C233	1-163-117-00	CERAMIC CHIP	100PF	10%	50V
C234	1-163-110-00	CERAMIC CHIP	51PF	10%	50V
C235	1-123-661-00	ELECT	100MF	20%	6.3V
C236	1-123-661-00	ELECT	100MF	20%	6.3V
C237	1-123-607-00	ELECT	0.1MF	20%	50V
C238	1-163-021-00	CERAMIC CHIP	0.01MF	10%	50V
C239	1-163-021-00	CERAMIC CHIP	0.01MF	10%	50V
C240	1-163-001-00	CERAMIC CHIP	220PF	10%	50V
C241	1-123-607-00	ELECT	0.1MF	20%	50V
C242	1-163-022-00	CERAMIC CHIP	0.012MF	10%	50V
C243	1-123-647-00	ELECT	47MF	20%	6.3V
C244	1-123-611-00	ELECT	1MF	20%	50V
C245	1-123-618-00	ELECT	22MF	20%	6.3V
C246	1-123-618-00	ELECT	22MF	20%	6.3V
C247	1-123-647-00	ELECT	47MF	20%	6.3V
C248	1-163-077-00	CERAMIC CHIP	0.1MF		50V
C249	1-123-647-00	ELECT	47MF	20%	6.3V
C401	1-161-013-00	CERAMIC	0.01MF	10%	25V
C701	1-108-427-12	MYLAR	0.033MF	5%	200V
C702	1-123-647-00	ELECT	47MF	20%	6.3V
C703	1-108-377-00	MYLAR	0.01MF	10%	100V
C704	1-108-373-00	MYLAR	0.0047MF	10%	100V
C901	1-102-074-00	CAP, CERAMIC	0.001MF B		
C902	1-102-074-00	CAP, CERAMIC	0.001MF B		
C903	1-102-074-00	CAP, CERAMIC	0.001MF B		
D101	8-719-815-55	DIODE	1S1555		
D102	8-719-422-21	DIODE	1T22AM		
D103	8-719-815-55	DIODE	1S1555		
D104	8-719-422-21	DIODE	1T22AM		
D105	8-719-422-21	DIODE	1T22AM		
D106	8-719-139-07	DIODE	RD3.9E-B		
D107	8-719-815-55	DIODE	1S1555		
D108	8-719-422-21	DIODE	1T22AM		
D109	8-719-815-55	DIODE	1S1555		
D201	8-719-815-55	DIODE	1S1555		
D202	8-719-815-55	DIODE	1S1555		
D203	8-719-815-55	DIODE	1S1555		
D204	8-719-815-55	DIODE	1S1555		
D205	8-719-815-55	DIODE	1S1555		
D206	8-719-815-55	DIODE	1S1555		
D207	8-719-815-55	DIODE	1S1555		
D701	8-719-909-21	DIODE	GL-9PR21		
D702	8-719-930-32	DIODE	GL-3PR2		
HE901	8-825-724-00	HEAD, ERASE	EF-201-36		
HP901	8-829-361-20	HEAD, MONITOR	(PP153-61B)		

NOTE:

- The mechanical parts with no reference number in the exploded views are not supplied.
- Items marked "▲" are not stocked since they are seldom required for routine service. Some delay should be anticipated when ordering these items.
- Due to standardization, parts with part numbers (Δ-ΔΔΔ-ΔΔΔ-XX or Δ-ΔΔΔΔ-ΔΔΔ-X) may be different from those used in the set.
- If there are two or more same circuits in a set such as a stereophonic machine, only typical circuit parts may be indicated and capacitors and resistors in other same circuits may be omitted.

CAPACITORS:

MF:μF, PF:μμF.

RESISTORS

All resistors are in ohms.

F: nonflammable

COILS

MMH: mH, UH: μH

SEMICONDUCTORS

In each case, U: μ, for example:

UA...: μA...; UPA...: μPA...; UPC...: μPC,

UPD...: μPD...

ELECTRICAL PARTS

Ref.No.	Part No.	Description			
HRP901	8-825-711-70	HEAD, R/P	(PF180-3602G)		
IC101	8-759-832-10	IC	LA3210		
IC102	8-759-272-07	IC	TA7207P		
IC103	1-806-020-21	IC	TK10040		
IC201	8-759-135-80	IC	UPC358C		
IC202	8-759-135-80	IC	UPC358C		
IC203	8-759-729-03	IC	NJM2903D		
IC204	8-759-400-15	IC	MN3205		
J101	1-507-722-00	JACK	3P		
J102	1-507-626-00	JACK, POWER	OUTSIDE		
J902	1-507-591-00	JACK			
JP1	1-216-295-00	METAL CHIP	0	5%	1/10W
JP2	1-216-295-00	METAL CHIP	0	5%	1/10W
JP3	1-216-295-00	METAL CHIP	0	5%	1/10W
JP4	1-216-295-00	METAL CHIP	0	5%	1/10W
JP5	1-216-295-00	METAL CHIP	0	5%	1/10W
JP6	1-216-296-00	METAL CHIP	0	5%	1/8W
JP7	1-216-296-00	METAL CHIP	0	5%	1/8W
JP8	1-216-296-00	METAL CHIP	0	5%	1/8W
JP9	1-216-296-00	METAL CHIP	0	5%	1/8W
JP10	1-216-296-00	METAL CHIP	0	5%	1/8W
JP11	1-216-296-00	METAL CHIP	0	5%	1/8W
JP12	1-216-296-00	METAL CHIP	0	5%	1/8W
JW113▲	1-535-149-11	WIRE	(30.0MM)		
JW114▲	1-535-149-11	WIRE	(30.0MM)		
L101	1-407-502-00	MICRO INDUCTOR	6.8MMH		
M901	8-835-060-01	MOTOR, DC	(DNE-2603A)		
ME901	1-520-433-00	METER, LEVEL			
MIC901	8-814-189-31	MICROPHONE, BUILT-IN	(C-1007A)		
PL901	1-518-293-00	LAMP PILOT			
Q101	8-729-245-83	TRANSISTOR	2SC2458		
Q102	8-729-245-83	TRANSISTOR	2SC2458		
Q103	8-729-245-83	TRANSISTOR	2SC2458		
Q104	8-729-334-58	TRANSISTOR	2SC1345		
Q105	8-729-663-47	TRANSISTOR	2SC1364		
Q106	8-729-663-47	TRANSISTOR	2SC1364		
Q107	8-729-663-47	TRANSISTOR	2SC1364		
Q108	8-729-663-47	TRANSISTOR	2SC1364		
Q109	8-729-173-37	TRANSISTOR	2SA733-P		
Q110	8-729-100-13	TRANSISTOR	2SC2001		
Q111	8-729-663-47	TRANSISTOR	2SC1364		
Q112	8-729-600-18	TRANSISTOR	2SC663-SP8		
Q113	8-729-663-47	TRANSISTOR	2SC1364		

ELECTRICAL PARTS

Ref.No.	Part No.	Description				
Q114	8-729-663-47	TRANSISTOR	2SC1364			
Q115	8-729-100-13	TRANSISTOR	2SC2001			
Q116	8-729-663-47	TRANSISTOR	2SC1364			
Q201	8-729-245-83	TRANSISTOR	2SC2458			
Q202	8-729-245-83	TRANSISTOR	2SC2458			
Q203	8-729-245-83	TRANSISTOR	2SC2458			
Q204	8-729-245-83	TRANSISTOR	2SC2458			
Q205	8-729-245-83	TRANSISTOR	2SC2458			
Q206	8-729-245-83	TRANSISTOR	2SC2458			
Q207	8-729-245-83	TRANSISTOR	2SC2458			
Q208	8-729-245-83	TRANSISTOR	2SC2458			
Q209	8-729-245-83	TRANSISTOR	2SC2458			
Q210	8-729-245-83	TRANSISTOR	2SC2458			
Q211	8-729-245-83	TRANSISTOR	2SC2458			
Q212	8-729-245-83	TRANSISTOR	2SC2458			
Q213	8-729-245-83	TRANSISTOR	2SC2458			
Q214	8-729-612-77	TRANSISTOR	2SA1027R			
Q215	8-729-612-77	TRANSISTOR	2SA1027R			
Q216	8-729-606-33	TRANSISTOR	2SC2603-F			
Q217	8-729-606-33	TRANSISTOR	2SC2603-F			
Q218	8-729-245-83	TRANSISTOR	2SC2458			
Q219	8-729-612-77	TRANSISTOR	2SA1027R			
Q220	8-729-245-83	TRANSISTOR	2SC2458			
Q221	8-729-612-77	TRANSISTOR	2SA1027R			
Q222	8-729-245-83	TRANSISTOR	2SC2458			
Q223	8-729-245-83	TRANSISTOR	2SC2458			
Q224	8-729-606-33	TRANSISTOR	2SC2603-F			
Q701	8-729-805-13	TRANSISTOR	2SC1475-13			
R101	1-247-823-00	CARBON	470	5%	1/6W	
R102	1-247-833-00	CARBON	1.2K	5%	1/6W	
R103	1-247-879-00	CARBON	100K	5%	1/6W	
R104	1-247-843-00	CARBON	3.3K	5%	1/6W	
R105	1-247-821-00	CARBON	390	5%	1/6W	
R106	1-247-825-00	CARBON	560	5%	1/6W	
R107	1-247-823-00	CARBON	470	5%	1/6W	
R108	1-247-900-00	CARBON	750K	5%	1/6W	
R109	1-247-855-00	CARBON	10K	5%	1/6W	
R110	1-247-826-00	CARBON	620	5%	1/6W	
R111	1-247-900-00	CARBON	750K	5%	1/6W	
R112	1-247-855-00	CARBON	10K	5%	1/6W	
R113	1-247-822-00	CARBON	430	5%	1/6W	
R114	1-247-855-00	CARBON	10K	5%	1/6W	
R115	1-247-831-00	CARBON	1K	5%	1/6W	
R116	1-247-865-00	CARBON	27K	5%	1/6W	
R117	1-247-865-00	CARBON	27K	5%	1/6W	
R118	1-247-857-00	CARBON	12K	5%	1/6W	

ELECTRICAL PARTS

Ref.No.	Part No.	Description				
R119	1-247-795-00	CARBON	33	5%	1/6W	
R120	1-247-855-00	CARBON	10K	5%	1/6W	
R121	1-247-831-00	CARBON	1K	5%	1/6W	
R122	1-247-847-00	CARBON	4.7K	5%	1/6W	
R123	1-247-871-00	CARBON	47K	5%	1/6W	
R124	1-247-844-00	CARBON	3.6K	5%	1/6W	
R125	1-247-869-00	CARBON	39K	5%	1/6W	
R126	1-247-814-00	CARBON	200	5%	1/6W	
R127	1-247-879-00	CARBON	100K	5%	1/6W	
R128	1-247-862-00	CARBON	20K	5%	1/6W	
R129	1-247-839-00	CARBON	2.2K	5%	1/6W	
R130	1-247-810-00	CARBON	130	5%	1/6W	
R131	1-247-864-00	CARBON	24K	5%	1/6W	
R132	1-247-901-00	CARBON	820K	5%	1/6W	
R133	1-247-845-00	CARBON	3.9K	5%	1/6W	
R134	1-247-863-00	CARBON	22K	5%	1/6W	
R135	1-247-833-00	CARBON	1.2K	5%	1/6W	
R136	1-247-839-00	CARBON	2.2K	5%	1/6W	
R137	1-247-863-00	CARBON	22K	5%	1/6W	
R138	1-247-863-00	CARBON	22K	5%	1/6W	
R139	1-247-851-00	CARBON	6.8K	5%	1/6W	
R140	1-247-867-00	CARBON	33K	5%	1/6W	
R141	1-247-813-00	CARBON	180	5%	1/6W	
R142	1-247-867-00	CARBON	33K	5%	1/6W	
R143	1-247-107-00	CARBON	100	5%	1/4W	
R144	1-247-831-00	CARBON	1K	5%	1/6W	
R145	1-247-815-00	CARBON	220	5%	1/6W	
R146	1-247-855-00	CARBON	10K	5%	1/6W	
R147	1-247-857-00	CARBON	12K	5%	1/6W	
R148	1-247-849-00	CARBON	5.6K	5%	1/6W	
R149	1-247-855-00	CARBON	10K	5%	1/6W	
R150	1-247-807-00	CARBON	100	5%	1/6W	
R151	1-247-101-00	CARBON	56	5%	1/4W	
R152	1-247-873-00	CARBON	56K	5%	1/6W	
R153	1-247-857-00	CARBON	12K	5%	1/6W	
R154	1-247-844-00	CARBON	3.6K	5%	1/6W	
R155	1-247-868-00	CARBON	36K	5%	1/6W	
R156	1-247-807-00	CARBON	100	5%	1/6W	
R157	1-247-866-00	CARBON	30K	5%	1/6W	
R158	1-247-876-00	CARBON	75K	5%	1/6W	
R159	1-247-831-00	CARBON	1K	5%	1/6W	
R160	1-247-863-00	CARBON	22K	5%	1/6W	
R161	1-247-855-00	CARBON	10K	5%	1/6W	
R162	1-247-783-00	CARBON	10	5%	1/6W	
R163	1-247-820-00	CARBON	360	5%	1/6W	
R164	1-247-831-00	CARBON	1K	5%	1/6W	

NOTE:

- The mechanical parts with no reference number in the exploded views are not supplied.
- Items marked "●" are not stocked since they are seldom required for routine service. Some delay should be anticipated when ordering these items.
- Due to standardization, parts with part numbers (Δ-ΔΔΔ-ΔΔΔ-XX or Δ-ΔΔΔΔ-ΔΔΔ-X) may be different from those used in the set.
- If there are two or more same circuits in a set such as a stereophonic machine, only typical circuit parts may be indicated and capacitors and resistors in other same circuits may be omitted.

CAPACITORS:

MF:μF, PF:μμF.

RESISTORS

All resistors are in ohms.

F : nonflammable

COILS

MMH : mH, UH : μH

SEMICONDUCTORS

In each case, U : μ, for example:
 UA.... : μA...., UPA.... : μPA...., UPC.... : μPC....
 UPD.... : μPD....

ELECTRICAL PARTS

Ref.No.	Part No.	Description				
R165	1-247-829-00	CARBON	820	5%	1/6W	
R166	1-247-855-00	CARBON	10K	5%	1/6W	
R167	1-247-855-00	CARBON	10K	5%	1/6W	
R168	1-247-895-00	CARBON	470K	5%	1/6W	
R169	1-247-855-00	CARBON	10K	5%	1/6W	
R170	1-247-889-00	CARBON	270K	5%	1/6W	
R171	1-247-903-00	CARBON	1M	5%	1/6W	
R172	1-247-871-00	CARBON	47K	5%	1/6W	
R173	1-247-870-00	CARBON	43K	5%	1/6W	
R174	1-247-869-00	CARBON	39K	5%	1/6W	
R175	1-247-847-00	CARBON	4.7K	5%	1/6W	
R176	1-247-837-00	CARBON	1.8K	5%	1/6W	
R177	1-247-822-00	CARBON	430	5%	1/6W	
R178	1-247-850-00	CARBON	6.2K	5%	1/6W	
R179	1-247-198-00	CARBON	18	5%	1/2W	
R180	1-247-875-00	CARBON	68K	5%	1/6W	
R181	1-247-800-00	CARBON	51	5%	1/6W	
R182	1-247-807-00	CARBON	100	5%	1/6W	
R183	1-247-804-00	CARBON	75	5%	1/6W	
R184	1-210-825-00	SOLID	3.3M	5%	1/4W	
R185	1-247-886-00	CARBON	200K	5%	1/6W	
R186	1-247-863-00	CARBON	22K	5%	1/6W	
R187	1-247-873-00	CARBON	56K	5%	1/6W	
R188	1-247-883-00	CARBON	150K	5%	1/6W	
R189	1-247-862-00	CARBON	20K	5%	1/6W	
R190	1-247-851-00	CARBON	6.8K	5%	1/6W	
R191	1-247-855-00	CARBON	10K	5%	1/6W	
R192	1-247-879-00	CARBON	100K	5%	1/6W	
R193	1-247-863-00	CARBON	22K	5%	1/6W	
R194	1-247-867-00	CARBON	33K	5%	1/6W	
R195	1-247-886-00	CARBON	200K	5%	1/6W	
R196	1-247-815-00	CARBON	220	5%	1/6W	
R197	1-247-813-00	CARBON	180	5%	1/6W	
R198	1-247-863-00	CARBON	22K	5%	1/6W	
R199	1-247-855-00	CARBON	10K	5%	1/6W	
R201	1-216-073-00	METAL CHIP	10K	5%	1/10W	
R202	1-216-069-00	METAL CHIP	6.8K	5%	1/10W	
R203	1-216-097-00	METAL CHIP	100K	5%	1/10W	
R204	1-216-049-00	METAL CHIP	1K	5%	1/10W	
R205	1-216-222-00	METAL CHIP	10K	5%	1/8W	
R206	1-216-041-00	METAL CHIP	470	5%	1/10W	
R207	1-216-089-00	METAL CHIP	47K	5%	1/10W	
R208	1-216-037-00	METAL CHIP	330	5%	1/10W	
R209	1-216-105-00	METAL CHIP	220K	5%	1/10W	
R210	1-216-097-00	METAL CHIP	100K	5%	1/10W	
R211	1-216-089-00	METAL CHIP	47K	5%	1/10W	

ELECTRICAL PARTS

Ref.No.	Part No.	Description				
R212	1-216-043-00	METAL CHIP	560	5%	1/10W	
R213	1-216-057-00	METAL CHIP	2.2K	5%	1/10W	
R214	1-216-025-00	METAL CHIP	100	5%	1/10W	
R215	1-216-121-00	METAL CHIP	1M	5%	1/10W	
R216	1-216-025-00	METAL CHIP	100	5%	1/10W	
R217	1-216-097-00	METAL CHIP	100K	5%	1/10W	
R218	1-216-073-00	METAL CHIP	10K	5%	1/10W	
R219	1-216-057-00	METAL CHIP	2.2K	5%	1/10W	
R220	1-247-855-00	CARBON	10K	5%	1/6W	
R221	1-216-073-00	METAL CHIP	10K	5%	1/10W	
R222	1-216-089-00	METAL CHIP	47K	5%	1/10W	
R223	1-216-025-00	METAL CHIP	100	5%	1/10W	
R224	1-216-073-00	METAL CHIP	10K	5%	1/10W	
R225	1-216-097-00	METAL CHIP	100K	5%	1/10W	
R226	1-216-089-00	METAL CHIP	47K	5%	1/10W	
R227	1-216-073-00	METAL CHIP	10K	5%	1/10W	
R228	1-216-045-00	METAL CHIP	680	5%	1/10W	
R229	1-216-073-00	METAL CHIP	10K	5%	1/10W	
R230	1-216-069-00	METAL CHIP	6.8K	5%	1/10W	
R231	1-216-246-00	METAL CHIP	100K	5%	1/8W	
R232	1-216-222-00	METAL CHIP	10K	5%	1/8W	
R233	1-247-855-00	CARBON	10K	5%	1/6W	
R234	1-216-073-00	METAL CHIP	10K	5%	1/10W	
R235	1-216-073-00	METAL CHIP	10K	5%	1/10W	
R236	1-216-065-00	METAL CHIP	4.7K	5%	1/10W	
R237	1-216-097-00	METAL CHIP	100K	5%	1/10W	
R238	1-216-073-00	METAL CHIP	10K	5%	1/10W	
R239	1-216-097-00	METAL CHIP	100K	5%	1/10W	
R240	1-216-041-00	METAL CHIP	470	5%	1/10W	
R241	1-216-109-00	METAL CHIP	330K	5%	1/10W	
R242	1-216-049-00	METAL CHIP	1K	5%	1/10W	
R243	1-216-037-00	METAL CHIP	330	5%	1/10W	
R244	1-216-065-00	METAL CHIP	4.7K	5%	1/10W	
R245	1-216-121-00	METAL CHIP	1M	5%	1/10W	
R246	1-216-222-00	METAL CHIP	10K	5%	1/8W	
R247	1-247-855-00	CARBON	10K	5%	1/6W	
R248	1-216-057-00	METAL CHIP	2.2K	5%	1/10W	
R249	1-216-049-00	METAL CHIP	1K	5%	1/10W	
R250	1-216-043-00	METAL CHIP	560	5%	1/10W	
R251	1-216-073-00	METAL CHIP	10K	5%	1/10W	
R253	1-216-089-00	METAL CHIP	47K	5%	1/10W	
R254	1-216-061-00	METAL CHIP	3.3K	5%	1/10W	
R255	1-216-065-00	METAL CHIP	4.7K	5%	1/10W	
R256	1-216-246-00	METAL CHIP	100K	5%	1/8W	
R257	1-216-246-00	METAL CHIP	100K	5%	1/8W	
R258	1-216-113-00	METAL CHIP	470K	5%	1/10W	

NOTE:

- The mechanical parts with no reference number in the exploded views are not supplied.
- Items marked "▲" are not stocked since they are seldom required for routine service. Some delay should be anticipated when ordering these items.
- Due to standardization, parts with part numbers (Δ-ΔΔΔ-ΔΔΔ-XX or Δ-ΔΔΔΔ-ΔΔΔ-X) may be different from those used in the set.
- If there are two or more same circuits in a set such as a stereophonic machine, only typical circuit parts may be indicated and capacitors and resistors in other same circuits may be omitted.

CAPACITORS:

MF: μF, PF: μμF.

RESISTORS

• All resistors are in ohms.

• F : nonflammable

COILS

• MMH : mH, UH : μH

SEMICONDUCTORS

In each case, U : μ, for example:

UA...: μA..., UPA...: μPA..., UPC...: μPC,

UPD...: μPD...

ELECTRICAL PARTS

Ref.No.	Part No.	Description			
R259	1-216-097-00	METAL CHIP	100K	5%	1/10W
R260	1-216-065-00	METAL CHIP	4.7K	5%	1/10W
R261	1-216-073-00	METAL CHIP	10K	5%	1/10W
R262	1-216-072-00	METAL CHIP	9.1K	5%	1/10W
R263	1-216-075-00	METAL CHIP	12K	5%	1/10W
R264	1-216-073-00	METAL CHIP	10K	5%	1/10W
R265	1-216-073-00	METAL CHIP	10K	5%	1/10W
R266	1-216-072-00	METAL CHIP	9.1K	5%	1/10W
R267	1-216-075-00	METAL CHIP	12K	5%	1/10W
R268	1-216-073-00	METAL CHIP	10K	5%	1/10W
R269	1-216-167-00	METAL CHIP	51	5%	1/8W
R270	1-216-174-00	METAL CHIP	100	5%	1/8W
R271	1-216-045-00	METAL CHIP	680	5%	1/10W
R272	1-216-073-00	METAL CHIP	10K	5%	1/10W
R273	1-216-067-00	METAL CHIP	5.6K	5%	1/10W
R274	1-216-067-00	METAL CHIP	5.6K	5%	1/10W
R275	1-216-097-00	METAL CHIP	100K	5%	1/10W
R276	1-216-097-00	METAL CHIP	100K	5%	1/10W
R277	1-216-073-00	METAL CHIP	10K	5%	1/10W
R278	1-216-073-00	METAL CHIP	10K	5%	1/10W
R279	1-216-073-00	METAL CHIP	10K	5%	1/10W
R280	1-247-879-00	CARBON	100K	5%	1/6W
R281	1-216-081-00	METAL CHIP	22K	5%	1/10W
R282	1-216-073-00	METAL CHIP	10K	5%	1/10W
R283	1-216-049-00	METAL CHIP	1K	5%	1/10W
R284	1-216-073-00	METAL CHIP	10K	5%	1/10W
R285	1-216-073-00	METAL CHIP	10K	5%	1/10W
R286	1-216-033-00	METAL CHIP	220	5%	1/10W
R288	1-216-057-00	METAL CHIP	2.2K	5%	1/10W
R289	1-216-105-00	METAL CHIP	220K	5%	1/10W
R290	1-216-097-00	METAL CHIP	100K	5%	1/10W
R291	1-216-073-00	METAL CHIP	10K	5%	1/10W
R292	1-216-198-00	METAL CHIP	1K	5%	1/8W
R293	1-216-081-00	METAL CHIP	22K	5%	1/10W
R294	1-216-065-00	METAL CHIP	4.7K	5%	1/10W
R295	1-216-065-00	METAL CHIP	4.7K	5%	1/10W
R296	1-216-097-00	METAL CHIP	100K	5%	1/10W
R297	1-216-073-00	METAL CHIP	10K	5%	1/10W
R298	1-216-055-00	METAL CHIP	1.8K	5%	1/10W
R299	1-216-246-00	METAL CHIP	100K	5%	1/8W
R300	1-216-079-00	METAL CHIP	18K	5%	1/10W
R301	1-216-081-00	METAL CHIP	22K	5%	1/10W
R302	1-216-083-00	METAL CHIP	27K	5%	1/10W
R303	1-216-072-00	METAL CHIP	9.1K	5%	1/10W
R304	1-216-295-00	METAL CHIP	0	5%	1/10W

NOTE:

- The mechanical parts with no reference number in the exploded views are not supplied.
- Items marked "▲" are not stocked since they are seldom required for routine service. Some delay should be anticipated when ordering these items.
- Due to standardization, parts with part numbers (Δ-ΔΔΔ-ΔΔΔ-XX or Δ-ΔΔΔΔ-ΔΔΔ-X) may be different from those used in the set.
- If there are two or more same circuits in a set such as a stereophonic machine, only typical circuit parts may be indicated and capacitors and resistors in other same circuits may be omitted.

ELECTRICAL PARTS

Ref.No.	Part No.	Description			
R305	1-216-039-00	METAL CHIP	390	5%	1/10W
R701	1-247-805-00	CARBON	82	5%	1/6W
R702	1-247-867-00	CARBON	33K	5%	1/6W
R401	1-247-823-00	CARBON	470	5%	1/6W
R703	1-247-859-00	CARBON	15K	5%	1/6W
R704	1-247-869-00	CARBON	39K	5%	1/6W
R901	1-246-545-00	RES, CARBON	1M	1%	1/4W
RM501	8-749-016-01	DM-106A			
RV101	1-228-100-00	RES, VAR, CARBON	20K/50K		
RV102	1-228-113-00	RES, VAR, CARBON	20K		
RV103	1-226-236-00	RES, ADJ, CARBON	10K		
RV104	1-226-240-00	RES, ADJ, CARBON	200K		
RV901	1-228-112-00	RES, VAR, CARBON	10K		
S101	1-553-600-00	SWITCH, SLIDE			
S102	1-553-086-00	SWITCH, PUSH			
S401	1-554-509-21	SWITCH, SLIDE			
S402	1-552-573-00	SWITCH, SLIDE			
S901	1-514-346-00	SWITCH, LEAF			
S902	1-553-624-00	SWITCH, SLIDE			
SP901	1-503-013-00	SPEAKER			
T101	1-423-207-00	TRANSFORMER, INPUT			
T102	1-433-285-11	TRANSFORMER, BIAS OSCILLATION			
T701	1-433-284-11	TRANSFORMER, STEP UP			

CAPACITORS:

MF:μF, PF:μμF.

RESISTORS

- All resistors are in ohms.
- F: nonflammable

COILS

- MMH: mH, UH: μH

SEMICONDUCTORS

In each case, U: μ, for example:
 UA...: μA...; UPA...: μPA...; UPC...: μPC,
 UPD...: μPD...