

# TC-630

Canadian Model

E Model

US Model

AEP Model

UK Model

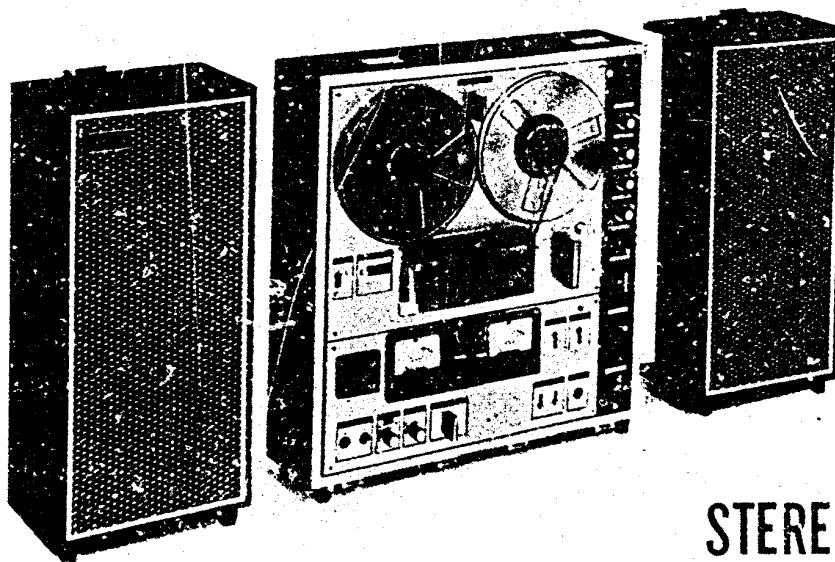

## STEREO TAPECORDER

### SPECIFICATIONS

<b>Power Requirements:</b>	85W (100 VA), 117 volts (USA, Canada Model) 85W, 100, 110, 117, 125, 220 & 240 volts (E, AEP, UK Model) (Voltage selector provided in the set) AC 60Hz (USA, Canada Model) AC 50 or 60 Hz (E, AEP, UK Model) (Convertible with power frequency selector and capstan sleeve)	<b>Outputs:</b>	Line outputs: 0 dB (0.775V), Load impedance 100k $\Omega$ Speaker outputs (for external): Load impedance 8 $\Omega$ Speaker outputs (for lid): Load impedance 16 $\Omega$ Headphone outputs (for monitoring): Load impedance 8 $\Omega$ Headphone outputs (for listening): Load impedance 8 $\Omega$
<b>Tape Speeds:</b>	19 cm/s, 9.5 cm/s and 4.8 cm/s 7 $\frac{1}{2}$ ips, 3 $\frac{3}{4}$ ips and 1 $\frac{7}{8}$ ips	<b>Recording Time:</b>	4-track stereo 1.5 hrs at 19cm/s, 7 $\frac{1}{2}$ ips 3 hrs at 9.5cm/s, 3 $\frac{3}{4}$ ips 6 hrs at 4.8cm/s, 1 $\frac{7}{8}$ ips
<b>Reel Size:</b>	7 inches or smaller		4-track mono 3 hrs at 19cm/s, 7 $\frac{1}{2}$ ips 6 hrs at 9.5cm/s, 3 $\frac{3}{4}$ ips 12 hrs at 4.8cm/s, 1 $\frac{7}{8}$ ips
<b>Track System:</b>	4-track stereophonic or monophonic	<b>Semiconductors:</b>	Transistor: 40 pcs. Diode: 7 pcs.
<b>Frequency Response:</b> (NAB)	30~22,000 Hz at 19cm/s, 7 $\frac{1}{2}$ ips 30~13,000 Hz at 9.5cm/s, 3 $\frac{3}{4}$ ips 30~10,000 Hz at 4.8cm/s, 1 $\frac{7}{8}$ ips	<b>Heads:</b>	Record: PP 30-2902A PP 102-2902 (Serial No. 124701 and later) Playback: RP30-2902 RP102-2902 (Serial No. 124701 and later) Erase: EF18-2902A
<b>Wow and Flutter:</b> (NAB)	Less than 0.09% at 19cm/s, 7 $\frac{1}{2}$ ips Less than 0.12% at 9.5cm/s, 3 $\frac{3}{4}$ ips Less than 0.16% at 4.8cm/s, 1 $\frac{7}{8}$ ips	<b>Dimensions:</b>	454(w) x 506 (h) x 294 (d) mm 17 $\frac{7}{8}$ (w) x 20 (h) x 11 $\frac{7}{8}$ (d) inches
<b>Power Output:</b>	15W (maximum) per channel 40W (dynamic power) with both channels	<b>Weight:</b>	21 kg, 46 lb 3 oz
<b>Signal-to-Noise Ratio</b>	Better than 50 dB		
<b>Harmonic Distortion:</b>	Less than 1.2% (at normal recording level) Less than 0.5% (in working as an amplifier)		
<b>Recording Level Indication:</b>	Two VU meters		
<b>Tone Controls:</b>	Two separate controls for bass and treble		
<b>Inputs:</b>	Low impedance microphone inputs: -72 dB (0.2 mV) High impedance auxiliary inputs: -22 dB (0.06V) High impedance tuner inputs: -22 dB (0.06V) Phonograph inputs: -52 dB (2 mV)		

# SONY

---

# SERVICE MANUAL

**TABLE OF CONTENTS**

<u>Section</u>	<u>Title</u>	<u>Page</u>
	Specifications .....	1
<b>1.</b>	<b>OUTLINE</b>	
	1-1. Block Diagram .....	3
	1-2. Cabinet Top View .....	4
	1-3. Cabinet Side Views (AEP, UK) .....	4
	1-4. Cabinet Side Views (USA, Canada).....	5
	1-5. Cabinet Side View (E) .....	5
	1-6. Chassis Side Views (USA, Canada) .....	6
	1-7. Chassis Top View .....	6
	1-8. Chassis Bottom View (AEP, UK).....	7
	1-9. Chassis Bottom View (E, USA, Canada) .....	7
<b>2.</b>	<b>DISASSEMBLY</b> .....	8
<b>3.</b>	<b>MAINTENANCE</b> .....	9
<b>4.</b>	<b>ADJUSTMENTS</b>	
	4-1. Mechanical Adjustments .....	11
	4-2. Adaptation to Different Power Line Frequency .....	15
	4-3. Electrical Adjustments .....	16
<b>5.</b>	<b>DIAGRAMS</b>	
	5-1. Wiring Diagram (E) .....	19
	5-2. Wiring Diagram (USA, Canada).....	22
	5-3. Mounting Diagrams.....	25
	Record Amp Circuit Board - Conductor Side - .....	25
	Trap & Dummy Coil Circuit Board - Conductor Side -.....	26
	Bias OSC Circuit Board - Conductor Side - .....	25
	Playback Amp Circuit Board - Conductor Side - .....	27
	Power Amp Circuit Board - Conductor Side - .....	28
	5-4. Schematic Diagram .....	29
	5-5. Level Diagrams .....	32
<b>6.</b>	<b>EXPLODED VIEWS</b>	
	6-1. Control Chassis - Top View - .....	33
	6-2. Chassis - Bottom View - .....	34
	6-3. Amp Chassis - Top View - .....	35
	6-4. Head Deck - Top View - .....	37
	6-5. Head Deck - Top View - Serial No. 124, 701 and later.....	38
	6-6. Chassis - Top View - .....	39
	6-7. Cabinet - Top View - .....	41
	6-8. Speaker Box - Top View - .....	42
<b>7.</b>	<b>ELECTRICAL PARTS LIST</b> .....	43
<b>8.</b>	<b>HARDWARE</b> .....	47

*When ordering replacement parts, use PART NUMBERS listed in Parts Lists or shown in EXPLODED VIEWS.*

*Parts List reference numbers should not be used.*

*All screws in this service manual are Phillips type (cross recess type) unless otherwise indicated.*

*(-) : slotted head*

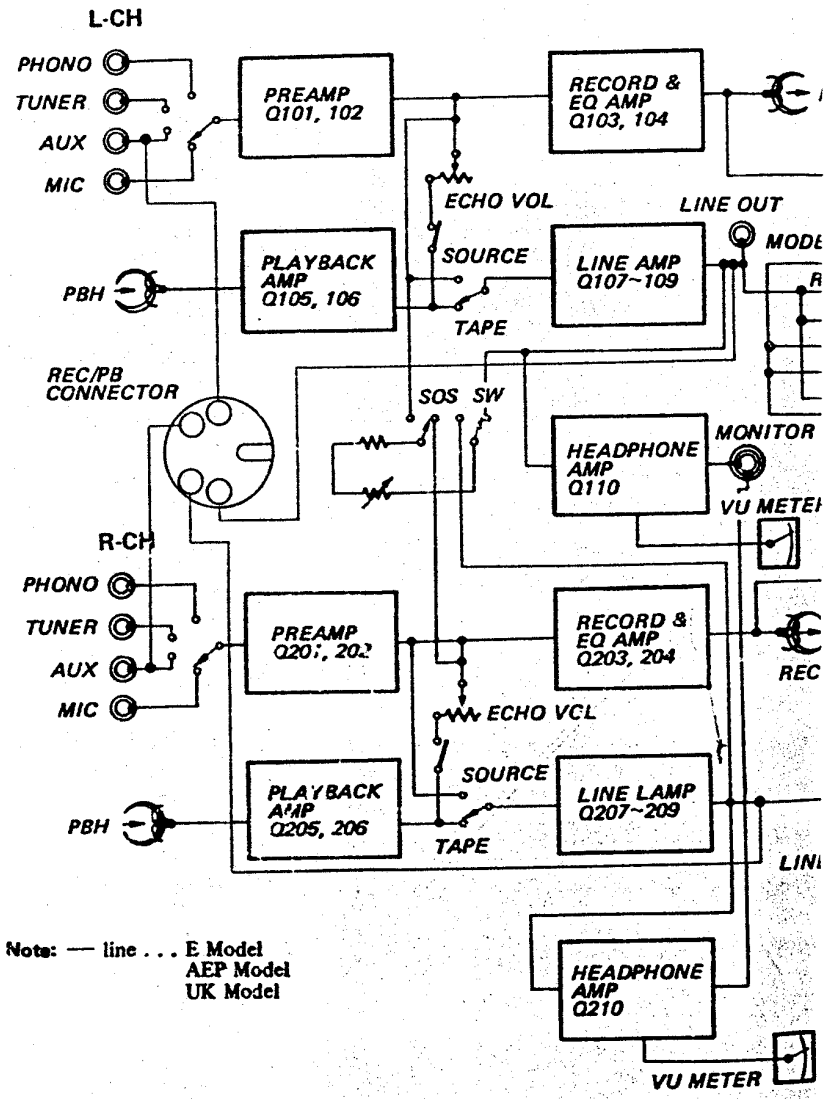

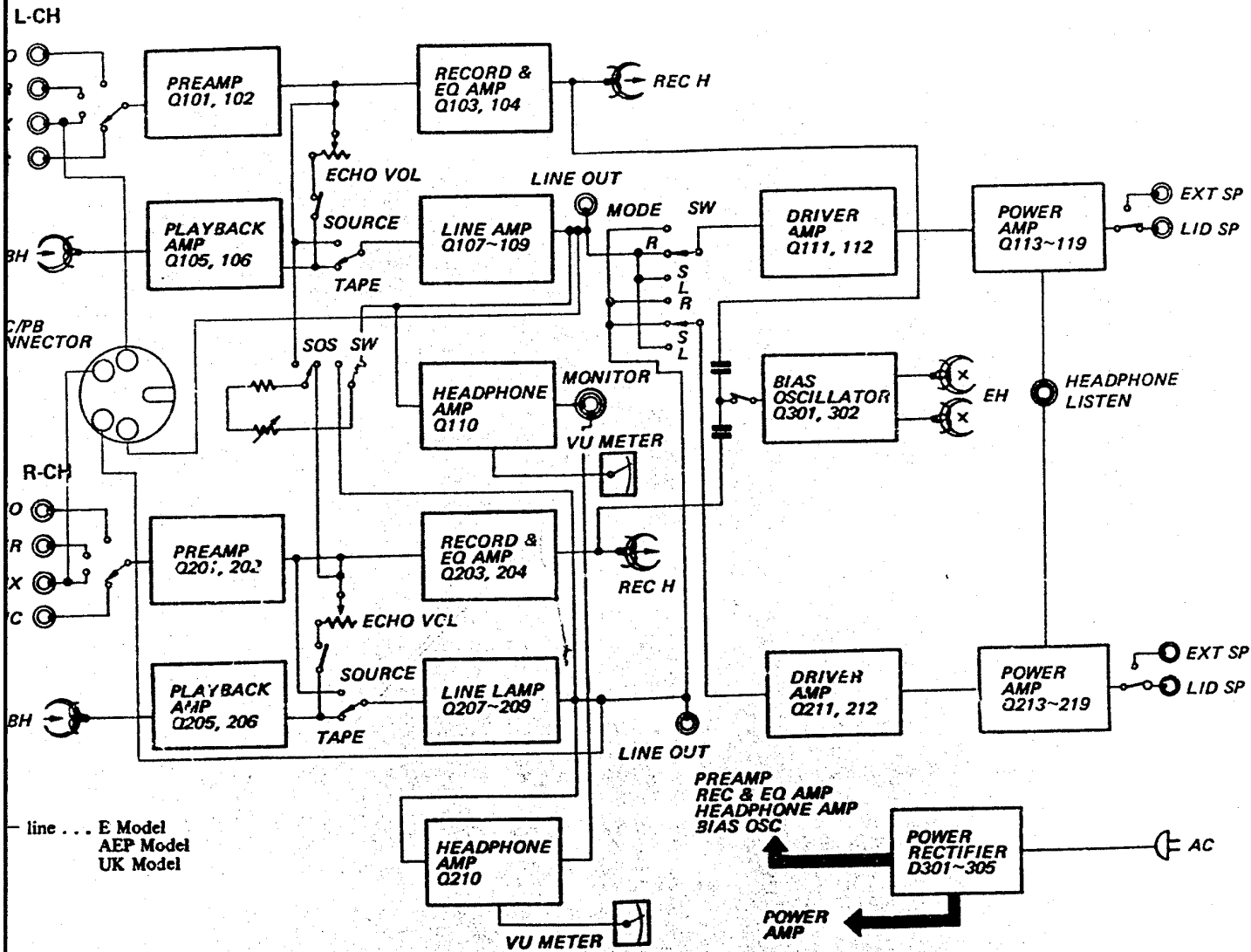

1-1. BLOCK DIAGRAM

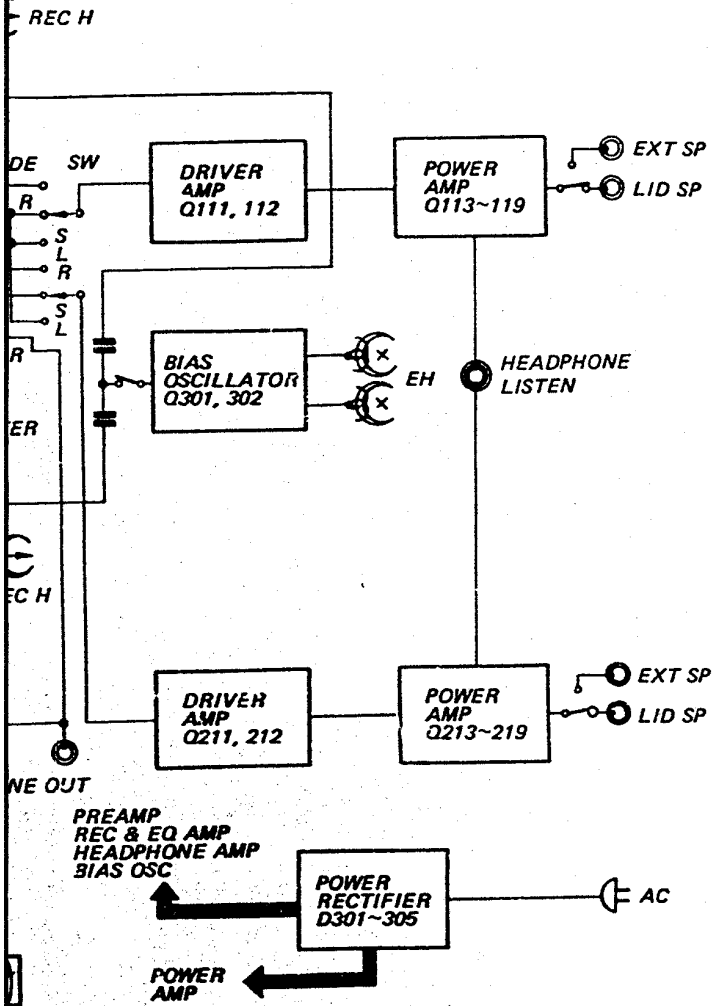

SECTION 1  
OUTLINE

TC-630

1-2 CABINET TOP VIEW

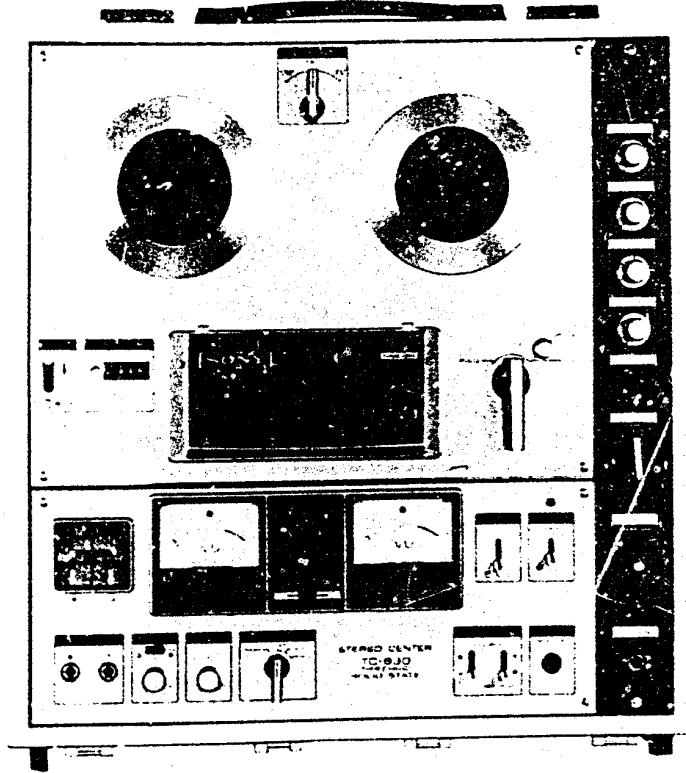

1-3. CABINET SIDE VIEWS (AEP, UK)

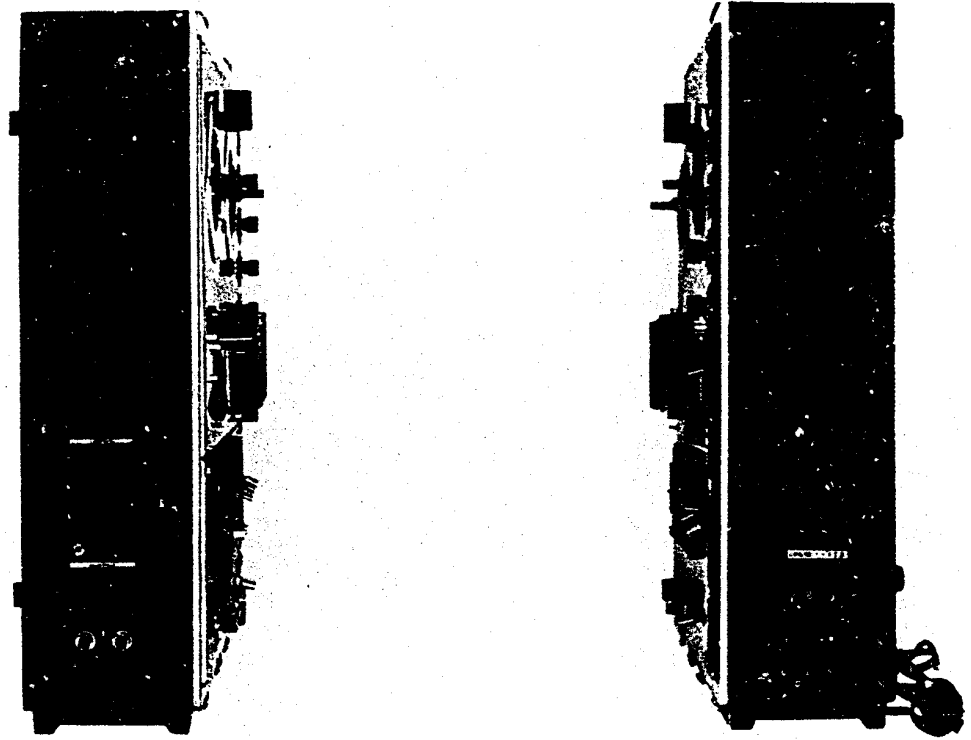

1-4. CABINET SIDE VIEWS (USA, Canada)

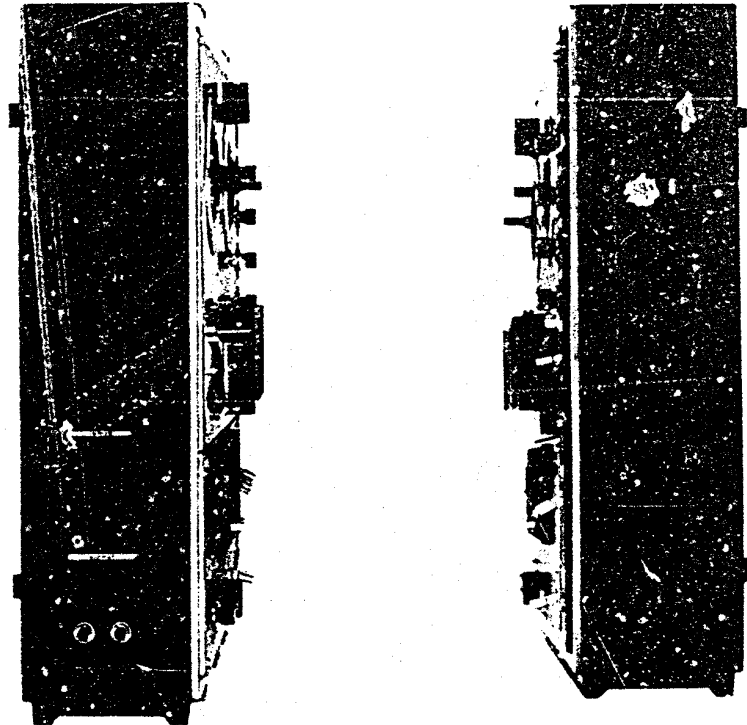

1-5. CABINET SIDE VIEWS (E)

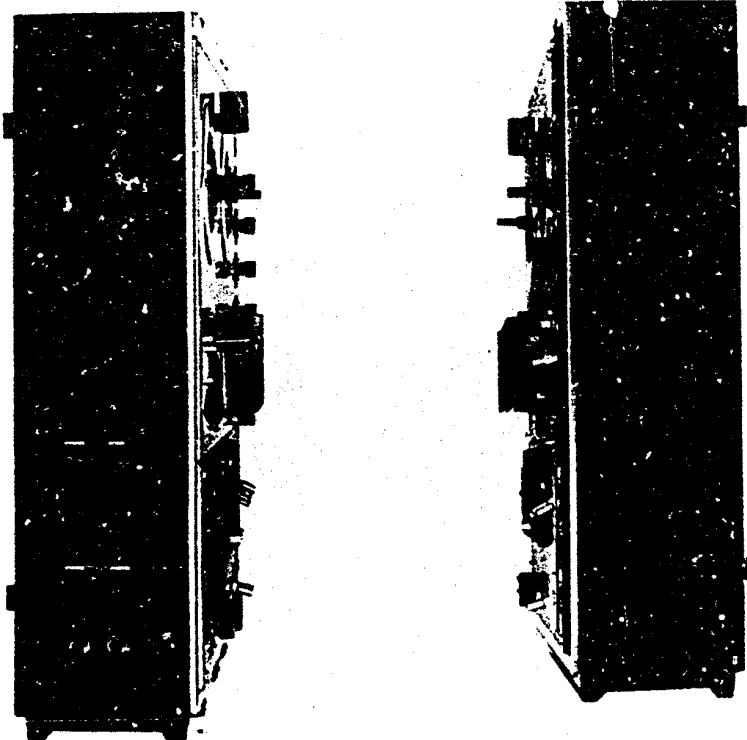

**1-6. CHASSIS SIDE VIEW (USA, Canada)**

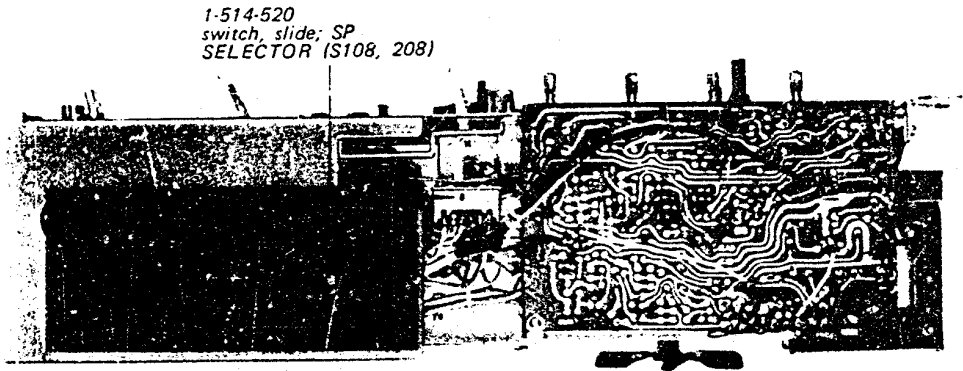

1-514-520  
switch, slide; SP  
SELECTOR (S108, 208)

**1-7. CHASSIS TOP VIEW**

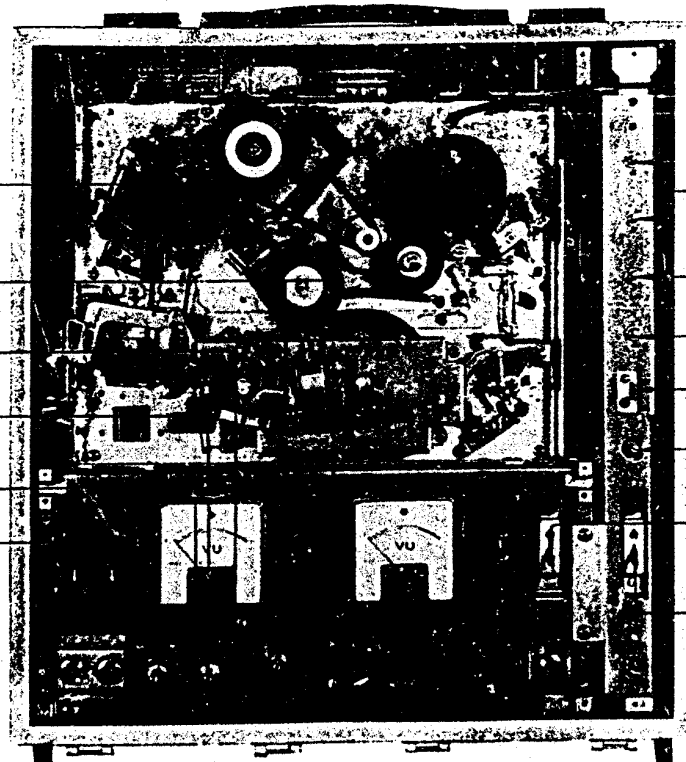

1-514-416  
switch, TAPE SPEED &  
equalizer (S103, 203, 301)

1-222-209  
resistor, 200kΩ (C);  
variable (R135, 235)

1-514-519  
switch, rotary; INPUT  
SELECTOR (S102, 202)

1-222-202  
resistor, 50KΩ (A); variable  
w/switch (R136, 236)

1-222-119  
resistor, 200KΩ (A);  
variable w/switch (R651)

1-514-449  
switch, rotary; SOS  
(S303)

1-221-916  
resistor 50kΩ (A);  
variable (R302, 304, 402, 404,

1-222-208  
resistor, 100KΩ;  
variable (R342)

1-221-916  
resistor, 50kΩ (A);  
variable (R308, 408)

1-514-520  
switch, slide;  
SP SELECTOR (S108, 208)

1-514-515  
switch, rotary; MODE  
selector (S109, 209)

1-516-037 (USA)  
1-514-852 (AEP, UK)  
1-514-325 (E, Canada)  
switch, lever; POWER (S305)

1-516-037 (USA)  
1-514-325 (AEP, UK)  
1-514-325 (E, Canada)  
switch, lever; POWER  
AMP (S306)

For Service Manuals  
**MAURITRON SERVICES**  
8 Cherry Tree Road, Chinnor  
Oxfordshire, OX9 4QY.  
Tel (01844) 351694  
Fax (01844) 352554  
email: mauritron@dial.pipex.com



1-8. CHASSIS BOTTOM VIEW (AEP, UK)

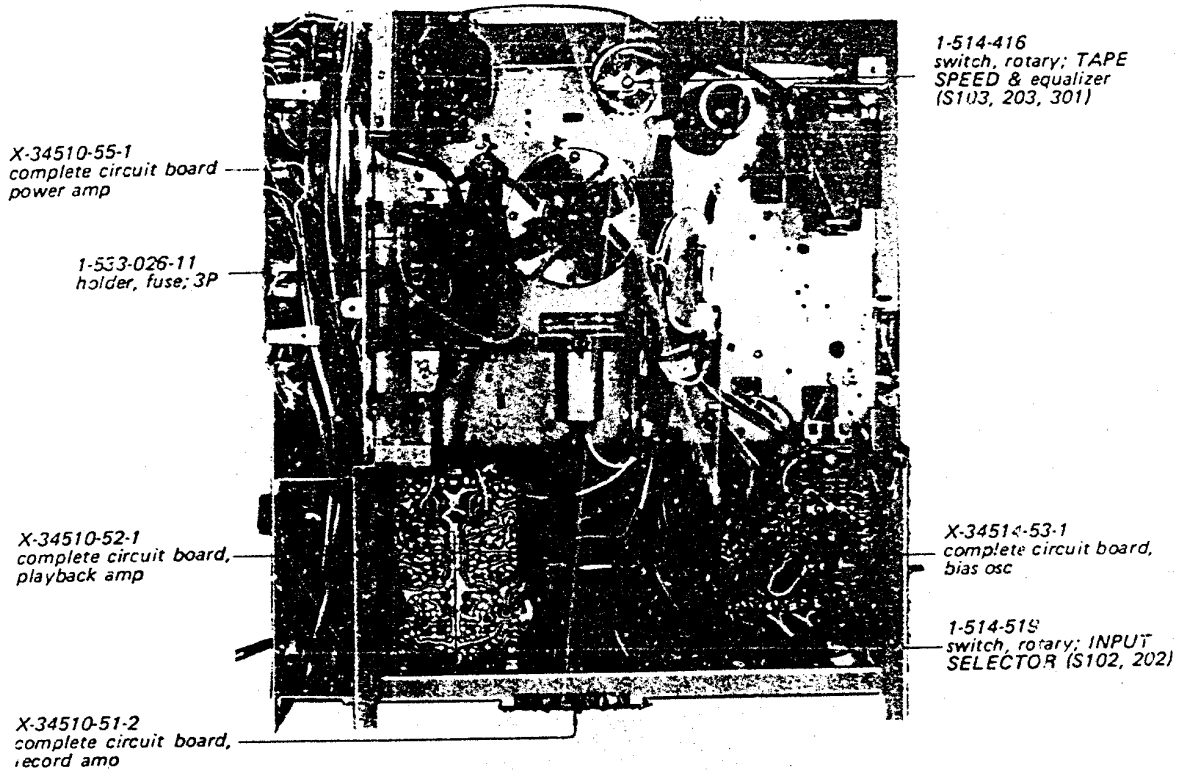

1-9. CHASSIS BOTTOM VIEW (E, USA, Canada)

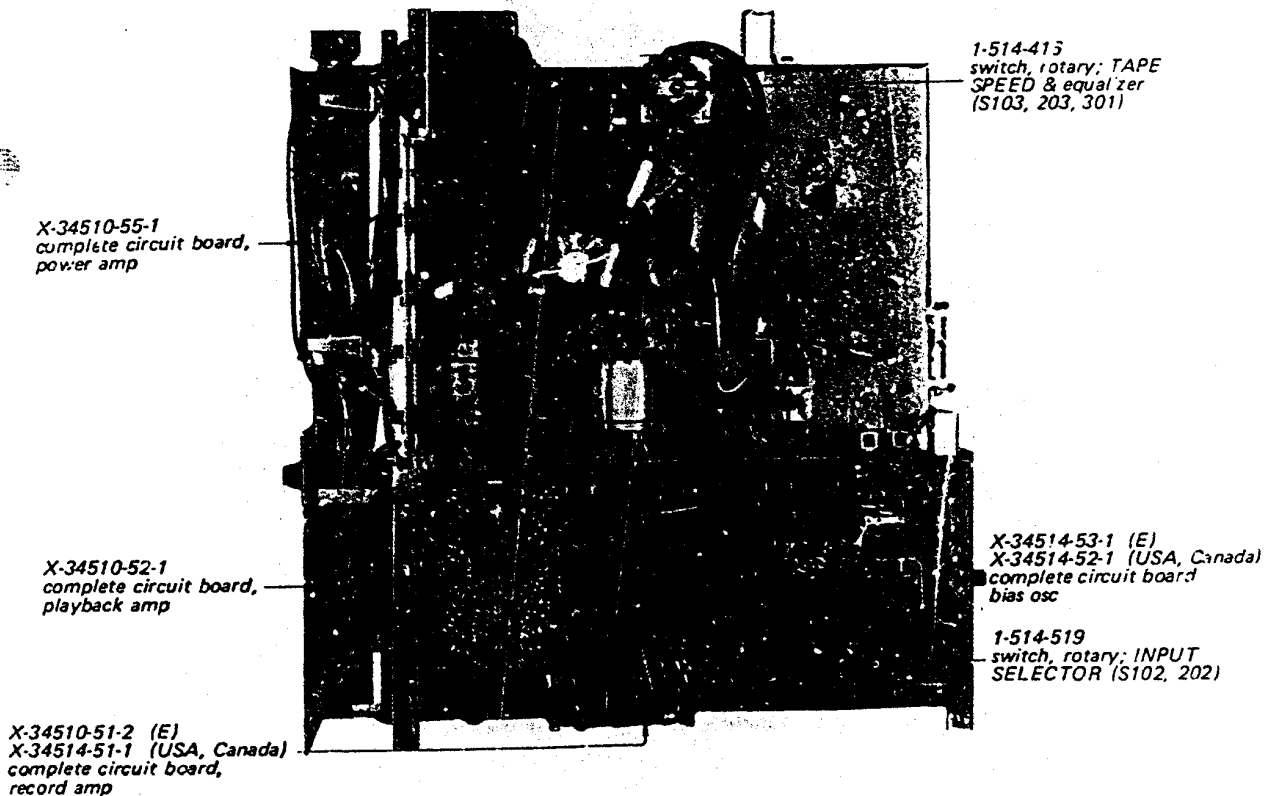

## SECTION 2 DISASSEMBLY

### 2-1. Knob and Head Cover Removal

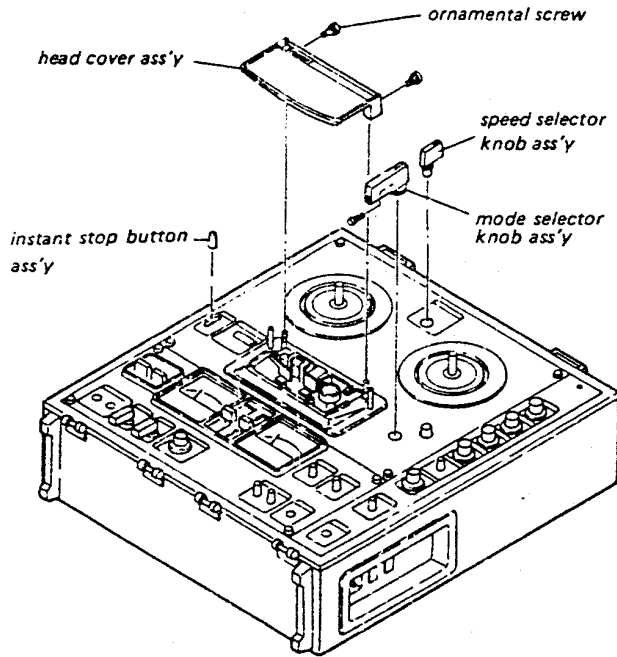

### 2-3. Handle Grip Removal

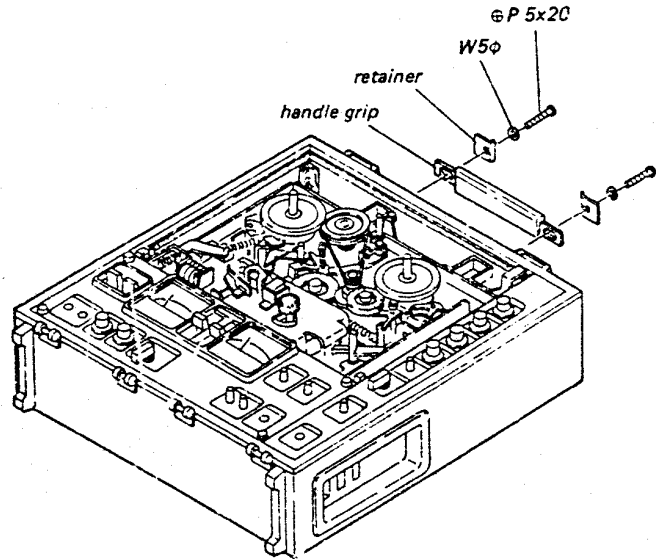

### 2-2. Reel Panel Removal

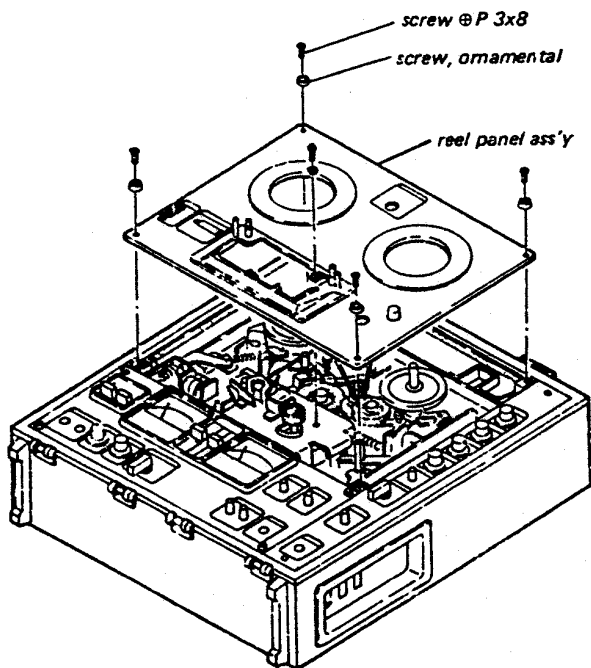

### 2-4. Cabinet Removal

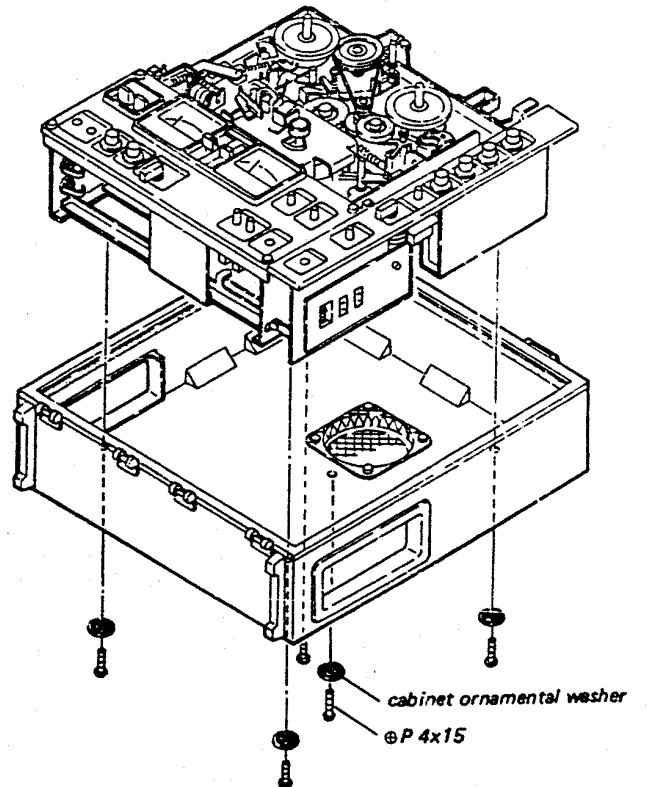

# SECTION 3 MAINTENANCE

## 3-1. Lubrication

The following parts of the tape transport mechanism require lubrication after two thousand hours of operation or once a year, whichever occurs first. Lubrication is important to insure proper operation of the equipment.

**Motor:** Motor requires 4 or 5 drops of SONY Oil (light machine oil).



*Fig. 3-1 Motor lubrication*

**Capstan:** Capstan requires 2 or 3 drops of SONY Oil (light machine oil).

**Pinch Roller:** Pinch Roller requires 2 or 3 drops of SONY Oil (light machine oil).

**Idler:** Idlers require lubrication only if they become noisy. Use no more than one drop of SONY Oil (light machine oil).

## CAUTION

If the oil is spilled on the rubber wheel or the belt, wipe it off immediately with denatured alcohol.

## 3-2. Cleaning

The following parts must be cleaned with a lintless cloth moistened with denatured alcohol for optimum performance.

- capstan
- pinch roller
- flywheel
- idlers
- tape roller
- heads

This cleaning is important for the tape threading path to prevent a loss of positive drive at capstan, dropouts, wow and flutter, or poor frequency response.

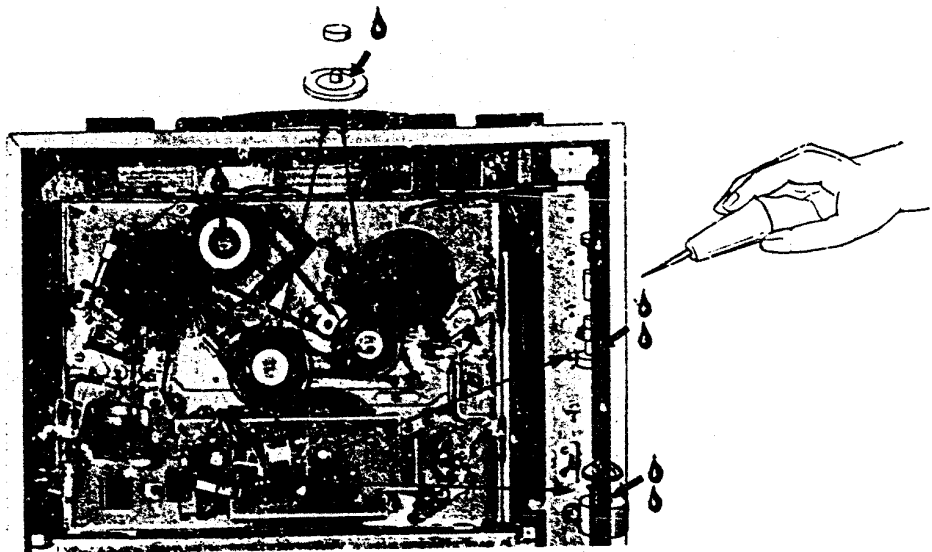

*Fig. 3-2 Lubrication*

# SECTION 4 ADJUSTMENTS

## 4.1. MECHANICAL ADJUSTMENT

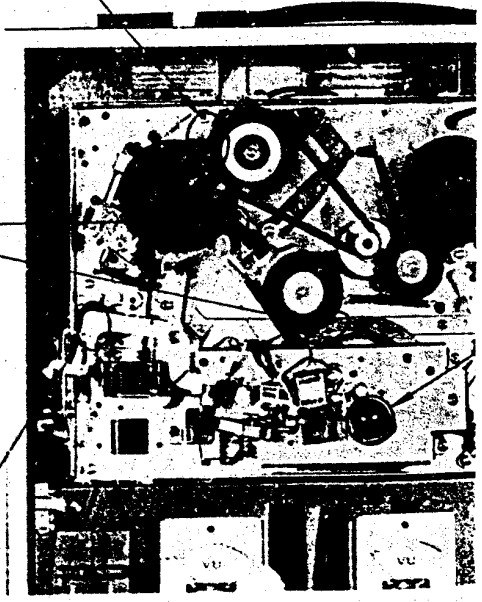
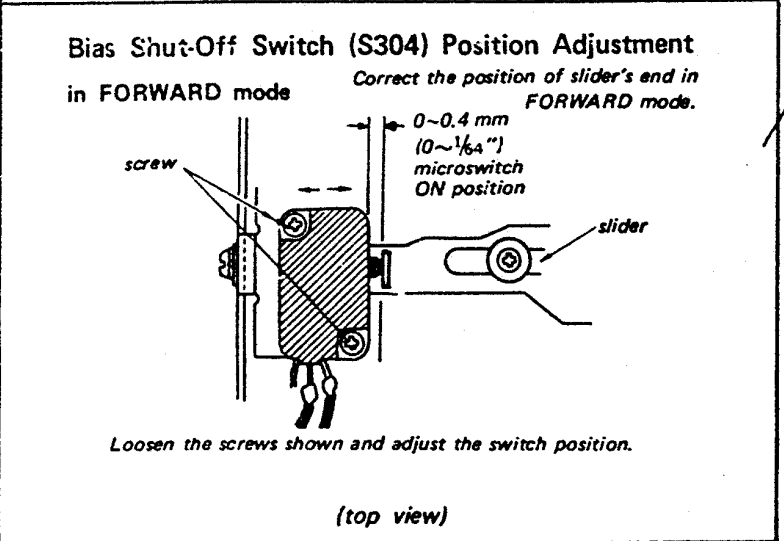
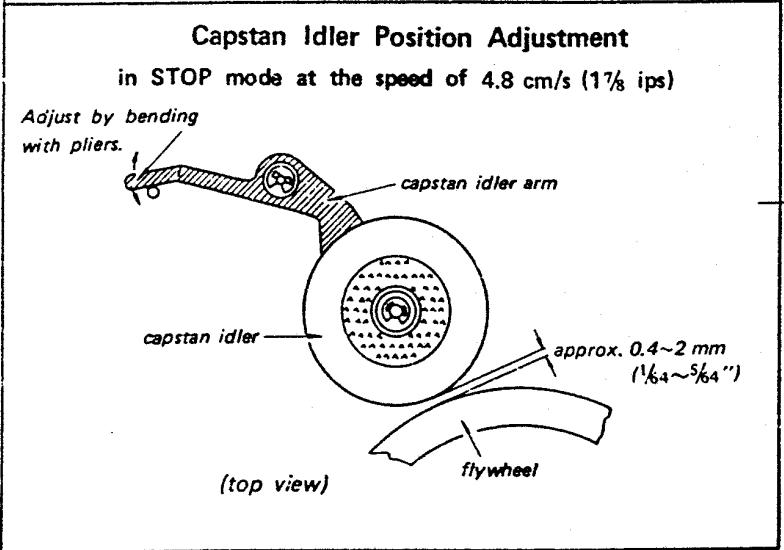
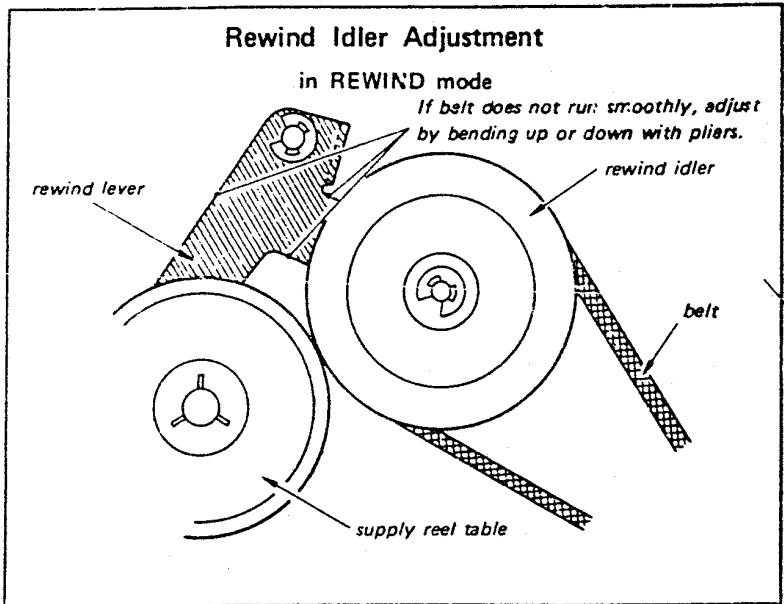

Adjustment locations

**SECTION 4  
ADJUSTMENTS**

**Adjustment**

**Mode**  
If belt does not run smoothly, adjust by bending up or down with pliers.

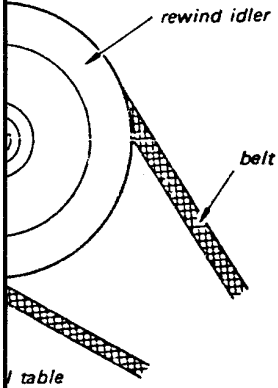

**Speed Adjustment**

to 4.8 cm/s (1 7/8 ips)

on idler arm

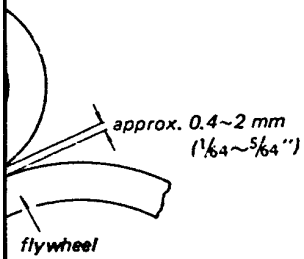

**Position Adjustment**

the position of slider's end in FORWARD mode.

0.4 mm (1/64")  
from switch position

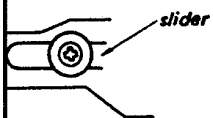

the switch position.

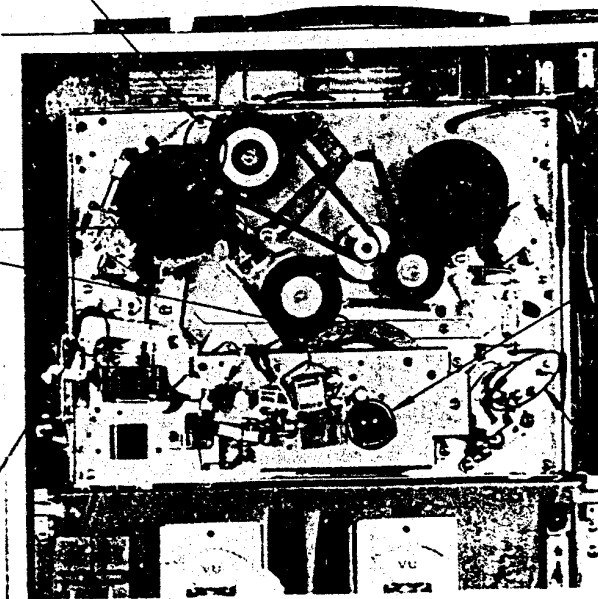

*Adjustment locations*

**Pinch Roller**

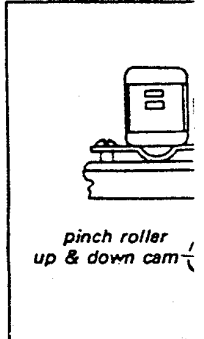

1. When  
Adjust by  
moving up

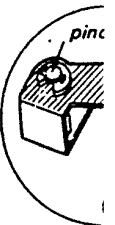

(b)

**FAST FORWARD**

approx.  
0.4 mm (1/64")

### Pinch Roller Shaft Height Adjustment

in FORWARD mode

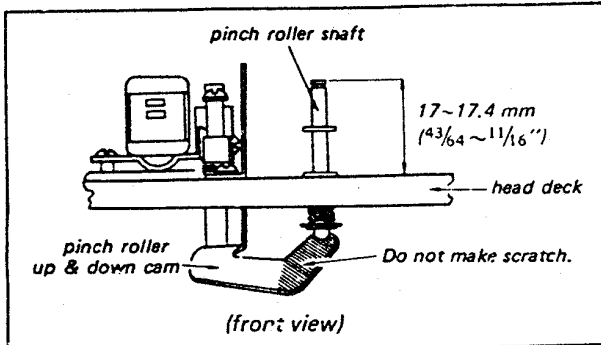

**1. When adjusting roughly**

Adjust by bending with pliers moving up or down as shown below.

**2. When adjusting accurately**

Adjust to obtain 17~17.4 mm ( $43/64 \sim 11/16''$ ) by loosening the screw and moving the shaft up or down. After fastening the screw, apply lock paint.

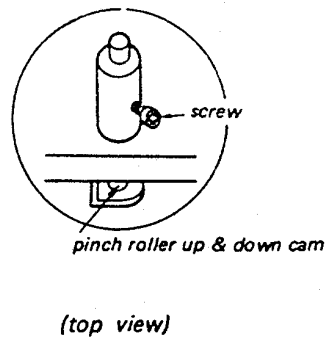
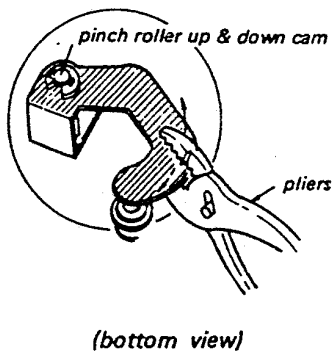

### FAST FORWARD Lever Position Adjustment

in FAST FORWARD mode

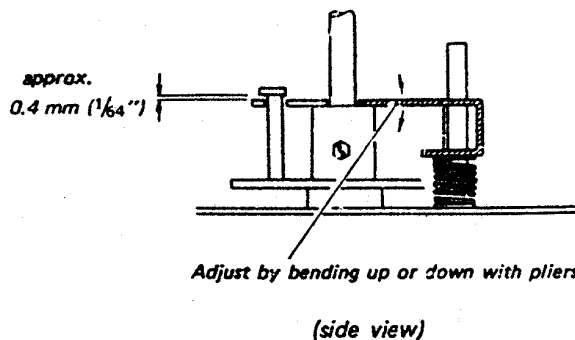

**Capstan Idler Slip Check**

in FORWARD mode at the speed of 4.8 cm/s (1 7/8 ips)

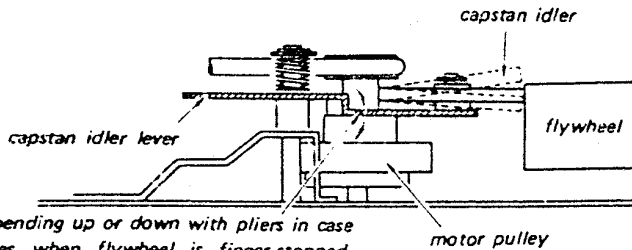

Adjust by bending up or down with pliers in case idler inclines when flywheel is finger-stopped. If idler slips, clean the surface of idler with denatured alcohol.

**Capstan Idler Height**  
in STOP mode at the speed

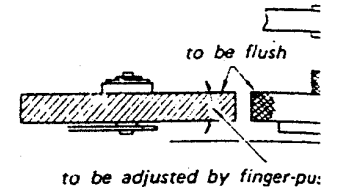

(side view)

**Instant Stop Lever Adjustment**

in FORWARD mode without capstan sleeve attached

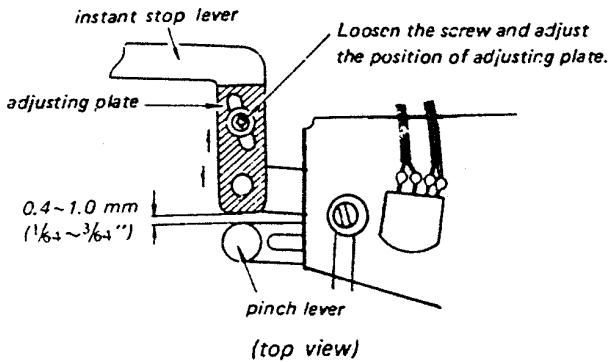

(top view)

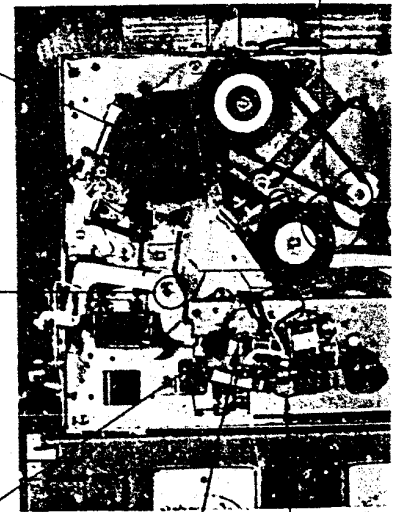

Located at the bottom side.

Adj

**Automatic Shut-Off Switch Adjustment**

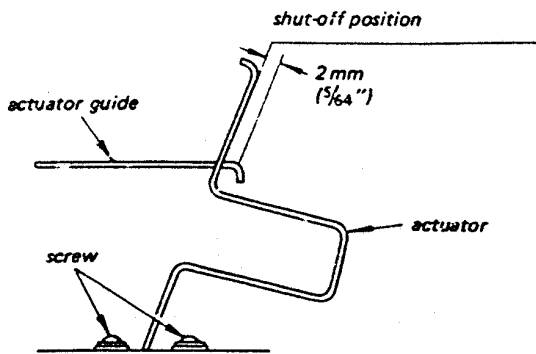

Loosen the screws and adjust by sliding microswitch holder.

(side view)

**Shifter Adjust**

in FORWARD mode

In forward mode, there should be the clearance as shown. In fast forward mode, tape sleeve should be attached. Loosen the screw and adjust by positioning the eraser head.

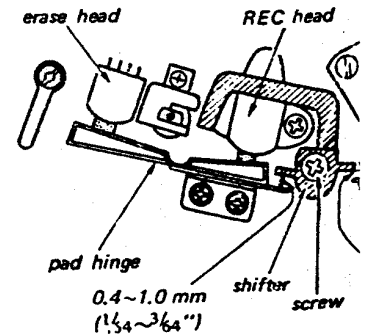

**Capstan Idler Height Adjustment**  
 in STOP mode at the speed of 19 cm/s (7 1/2 ips)

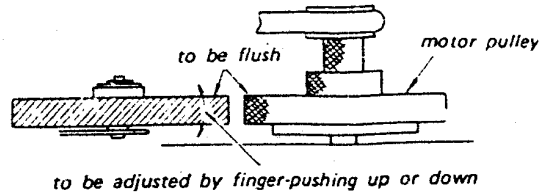
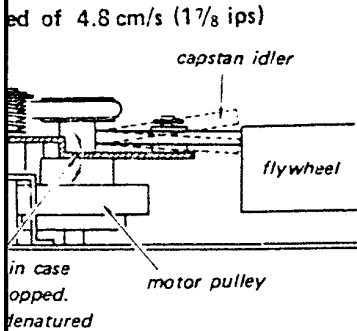

(side view)

**Capstan Adjustment**

capstan sleeve attached

Loosen the screw and adjust  
 the position of adjusting plate.

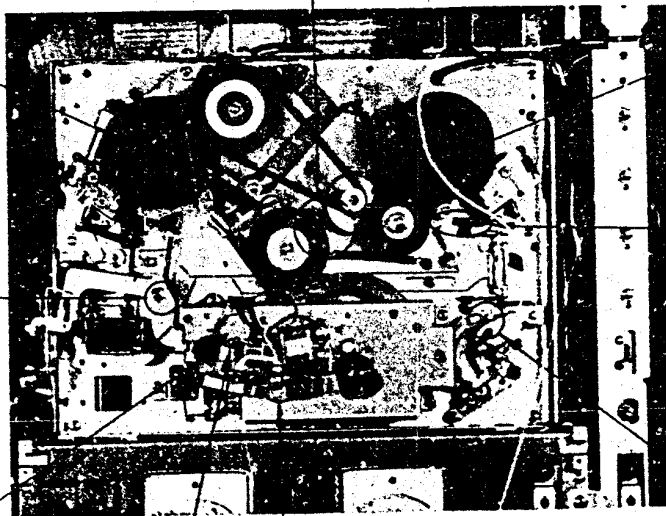
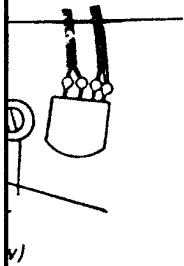

Located at the bottom side.

Adjustment locations

**Switch Adjustment**

position

mm  
 4")

actuator

by sliding microswitch holder.  
 view)

**Shifter Adjustment**

in FORWARD mode

In forward mode, there should be the clearance of 0.4~1.0 mm (1/64~3/64")  
 as shown. In fast forward mode, tape should not contact heads.  
 Make the adjustment with sleeve attached to capstan and without sleeve.  
 Loosen the screw and adjust by positioning shifter.

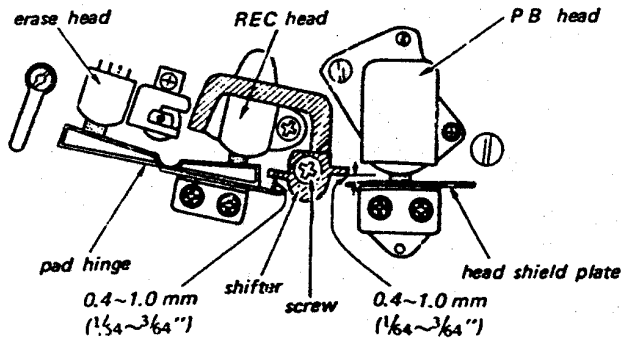



**Adjustment of 19 cm/s (7 1/2 ips)**

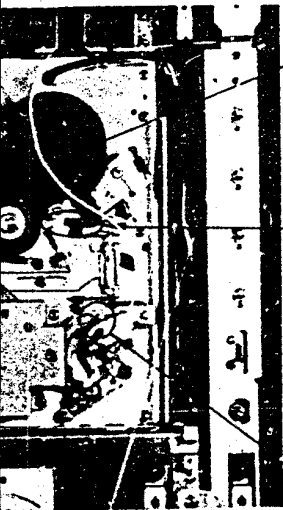
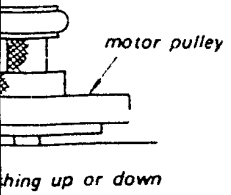

Adjustment locations

**Adjustment in FAST FORWARD mode**  
 Clearance of 0.4~1.0 mm (1/64~3/64") should not contact heads. Adjusted to capstan and without sleeve. Moving shifter.

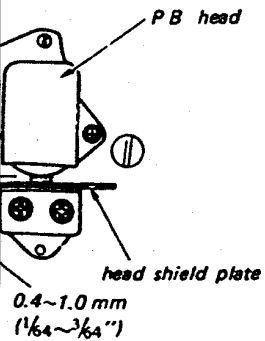

**Motor Pulley Height Adjustment in FORWARD mode at the speed of 4.8 cm/s (1 7/8 ips)**

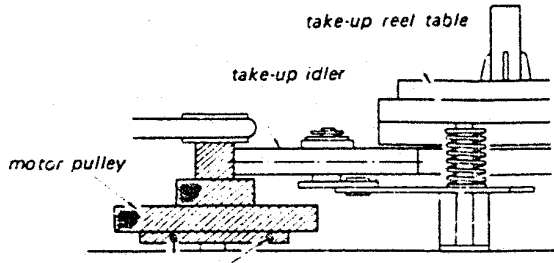

Loosen the screws and adjust the height of motor pulley so that take-up idler makes contact with the pulley as shown.

(side view)

**Take-up Idler Height Adjustment in FAST FORWARD mode**

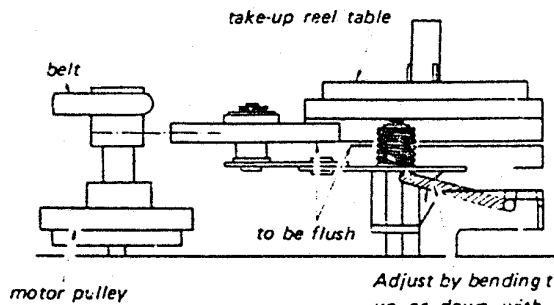

Adjust by bending this crank up or down with pliers.

(side view)

**Head Deck Position Adjustment in FORWARD mode**

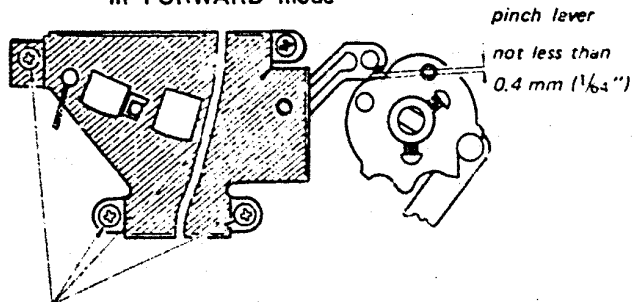

Loosen the screws and adjust the position of head deck.

(top view)

#### 4-2. ADAPTATION TO DIFFERENT POWER LINE FREQUENCY (AEP, E)

##### From 50 Hz to 60 Hz

Set the power frequency selector switch to 60 Hz and remove the capstan sleeve.

##### From 60 Hz to 50 Hz

Set the power frequency selector switch to 50 Hz and put on the capstan sleeve.

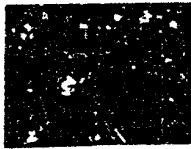

power frequency selector switch

Power frequency selector switch

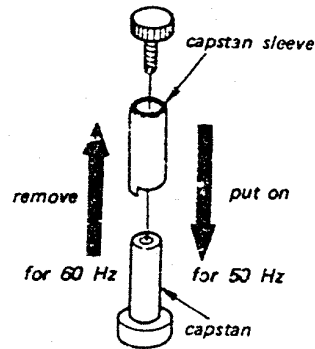

Capstan sleeve

For Service Manuals  
**MAURITRON SERVICES**  
8 Cherry Tree Road, Chinnor  
Oxfordshire, OX9 4QY.  
Tel (01844) 351694  
Fax (01844) 352554  
email- mauritron@dial.pipex.com

**4.3. ELECTRICAL ADJUSTMENTS**

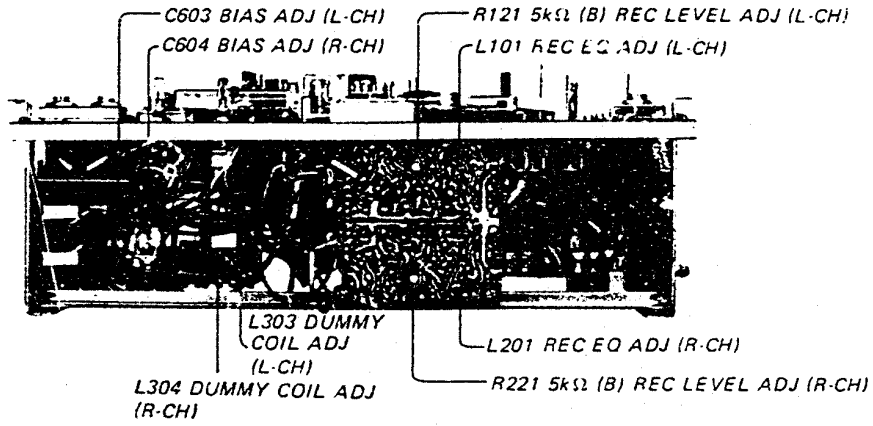

*Fig. 4-3-1 Adjustment location*

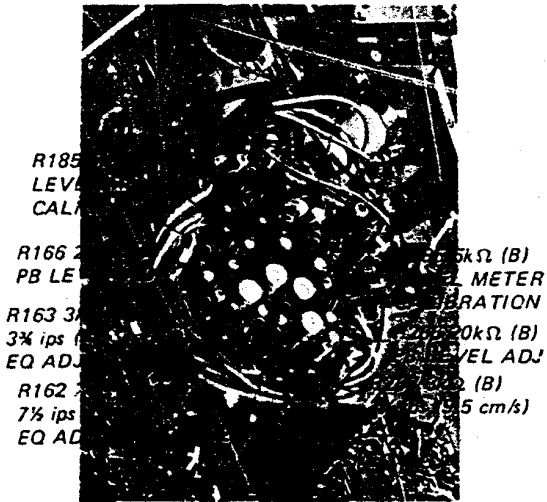

*Fig. 4-3-2 Adjustment location*

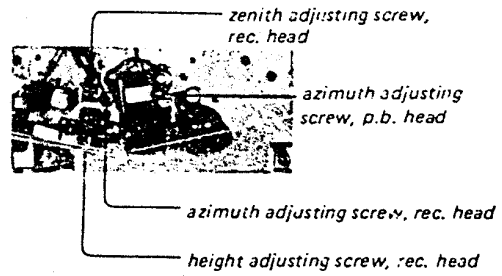

*Fig. 4-3-3 Adjusting screws*

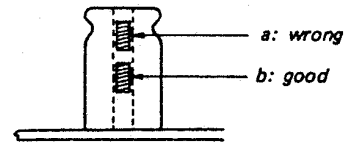

*Fig. 4-3-4 Core setting of L101 (L201)*

**Notes:**

1. Before making the adjustments, be sure to clean the heads with cloth or swab dampened with denatured alcohol and to demagnetize the record and playback heads with a head demagnetizer (SONY HE-2).
2. The adjustments should be made in numerical order.
3. The SOS switch and the NOISE SUPPRESS switch should be set in OFF position.
4. The adjustments should be made at 19 cm/s (7½ ips) tape speed except the item 3.

5. After the adjustments, apply lock paint to the parts adjusted.
6. The following test equipment is to be used for the adjustments:
  - ⊛ audio signal generator
  - ⊛ attenuator 600Ω
  - ⊛ VTVM
  - ⊛ SONY adjustment tape, J-19-F1 & J-19-F2

Item	Signal Source	Output Connection	Mode	
1. Playback Head Azimuth Adjustment	10 kHz, 3rd tone of SONY adjustment tape, J-19-F2 MONITOR switch: TAPE	VTVM and 100kΩ resistor in parallel with LINE OUT jack	PLAYBACK	playback adjusting See
2. Playback Level Adjustment and Level Meter Calibration	400 Hz, 1st tone of SONY adjustment tape, J-19-F2 MONITOR switch: TAPE	VTVM and 100kΩ resistor in parallel with LINE OUT jack	PLAYBACK	L-CH: R166 R185 See
3. Playback Equalizer Adjustment (1) 19 cm/s (7½ ips)	SONY adjustment tape, J-19-F2 MONITOR switch: TAPE	VTVM and 100kΩ resistor in parallel with LINE OUT jack	PLAYBACK	L-CH: See
(2) 9.5 cm/s (3¾ ips)	SONY adjustment tape, J-9-F1 MONITOR switch: TAPE			L-CH: See
4. Bias Trap Coil Adjustment	_____	VTVM to test point and ground (See page 25, TP)	RECORD	L-CH: See
5. Record Head Height Adjustment	1 kHz, -60 dB (0.78 mV) to MIC jack INPUT SELECTOR: MIC	VTVM and 100kΩ resistor in parallel with LINE OUT jack	RECORD	record head azimuth See
6. Record Head Azimuth Adjustment	15 kHz, -90 dB (24.5μV) to MIC jack INPUT SELECTOR: MIC	VTVM and 100kΩ resistor in parallel with LINE OUT jack	RECORD	record head screw See
7. Record Bias Adjustment	1 kHz, -60 dB (0.78 mV) to MIC jack INPUT SELECTOR: MIC	VTVM and 100kΩ resistor in parallel with LINE OUT jack	RECORD	L-CH: See
8. Record Level Adjustment	1 kHz, -60 dB (0.78 mV) to MIC jack INPUT SELECTOR: MIC	VTVM and 100kΩ resistor in parallel with LINE OUT jack	RECORD	L-CH: See
9. Record Equalizer Adjustment	1k, 20 kHz, -90 dB (24.5μV) to MIC jack INPUT SELECTOR: MIC	VTVM and 100kΩ resistor in parallel with LINE OUT jack	RECORD	L-CH: See
10. Dummy Coil Adjustment	_____	VTVM to test point (See page 25, TP)	RECORD	at motor L-CH:

# TC-630 TC-630

impregnated with denatured alcohol (NY HE-2).

ation.  
item 3.

5. After the adjustments, apply lock paint to the parts adjusted.
6. The following test equipment is to be used for the adjustments:
  - ☆ audio signal generator
  - ☆ attenuator 600Ω
  - ☆ VTVM
  - ☆ SONY adjustment tape, J-19-F1 & J-19-F2

- ☆ 100kΩ resistor
- 7. Bias voltages across the heads should be read on VTVM as follows:
  - record head: approx. 16 volts at 19 cm/s (7½ ips)
  - 14 volts at 9.5 cm/s (3¾ ips)
  - 12 volts at 4.8 cm/s (1¾ ips)
  - erase head: approx. 120 volts

Source	Output Connection	Mode	Adjust													
SONY adjustment: TAPE	VTVM and 100kΩ resistor in parallel with LINE OUT jack	PLAYBACK	playback head azimuth adjusting screw See Fig. 4-3-3.	Adjust the screw to obtain maximum												
SONY adjustment: TAPE	VTVM and 100kΩ resistor in parallel with LINE OUT jack	PLAYBACK	L-CH: R166 R185 R-CH: R266 (20kΩ; B) R285 (5kΩ; B) See Fig. 4-3-2.	1. Adjust R166 (L-CH) and R266 2. Adjust R185 (L-CH) and R285												
SONY adjustment: TAPE, J-19-F2	VTVM and 100kΩ resistor in parallel with LINE OUT jack	PLAYBACK	L-CH: R162 2kΩ (B) R-CH: R262 See Fig. 4-3-2.	Deviation against the level at 400 Hz <table border="1" style="width: 100%; border-collapse: collapse;"> <tr> <td>Tape tone</td> <td>4th</td> <td>5th</td> </tr> <tr> <td>Frequency</td> <td>12.5 kHz</td> <td>10 kHz</td> </tr> <tr> <td>L-CH</td> <td>0±2 dB</td> <td>0±2 dB</td> </tr> <tr> <td>R-CH</td> <td></td> <td></td> </tr> </table> After the adjustment, repeat the	Tape tone	4th	5th	Frequency	12.5 kHz	10 kHz	L-CH	0±2 dB	0±2 dB	R-CH		
Tape tone			4th	5th												
Frequency	12.5 kHz	10 kHz														
L-CH	0±2 dB	0±2 dB														
R-CH																
SONY adjustment: TAPE, J-9-F1			L-CH: R163 3kΩ (B) R-CH: R263 See Fig. 4-3-2.	Deviation against the level of 400 Hz <table border="1" style="width: 100%; border-collapse: collapse;"> <tr> <td>Tape tone</td> <td>4th</td> <td>5th</td> </tr> <tr> <td>Frequency</td> <td>5 kHz</td> <td>2.5 kHz</td> </tr> <tr> <td>L-CH</td> <td>0±2 dB</td> <td>0±2 dB</td> </tr> <tr> <td>R-CH</td> <td></td> <td></td> </tr> </table>	Tape tone	4th	5th	Frequency	5 kHz	2.5 kHz	L-CH	0±2 dB	0±2 dB	R-CH		
Tape tone	4th	5th														
Frequency	5 kHz	2.5 kHz														
L-CH	0±2 dB	0±2 dB														
R-CH																
	VTVM to test point and ground (See page 25, TP)	RECORD	L-CH: L301 1.8 mH R-CH: L302 See Fig. 4-3-1.	1. Set the REC VOL controls 2. Adjust to obtain minimum ripple												
78 mV to MIC MONITOR: MIC	VTVM and 100kΩ resistor in parallel with LINE OUT jack	RECORD	record head height, zenith and azimuth adjusting screw See Fig. 4-3-3.	1. Turn the three screws (height, zenith and azimuth) visually horizontal. 2. Set the MONITOR switch to RECORD. 3. Turn the height adjusting screw. Memorize the number of turns. 4. Turn the zenith and azimuth adjusting screws. 5. Follow the steps 3 and 4 to obtain minimum ripple.												
24.5μV to MIC MONITOR: MIC	VTVM and 100kΩ resistor in parallel with LINE OUT jack	RECORD	record head azimuth adjusting screw See Fig. 4-3-3.	1. Set the MONITOR switch to RECORD. 2. Turn the azimuth adjusting screw. Memorize the number of turns. 3. Turn the screw, the maximum ripple is obtained. 4. Turn the screw back to the number of turns memorized in step 2. 5. Follow the steps 3 and 4 to obtain minimum ripple.												
78 mV to MIC MONITOR: MIC	VTVM and 100kΩ resistor in parallel with LINE OUT jack	RECORD	L-CH: C603 30-200pF R-CH: C604 See Fig. 4-3-1.	1. Set the MONITOR switch to RECORD. 2. Turn the trimmer capacitors C603 and C604. Record the maximum ripple. 3. Recording the signal, turn the trimmer capacitors. Read the maximum ripple. 4. Continue to turn the capacitors. Read the VTVM reading. 5. Adjust the trimmer capacitors. Make sure that the reading is minimum. 6. Make sure that the reading is minimum. 7. If not, follow the steps 2-6.												
78 mV to MIC MONITOR: MIC	VTVM and 100kΩ resistor in parallel with LINE OUT jack	RECORD	L-CH: R121 5kΩ (B) R-CH: R221 See Fig. 4-3-1.	1. Set the MONITOR switches to RECORD. 2. Feeding the signal, slide the VU meter to 0 VU (100%). 3. Record the signal on a blank tape. 4. Set the MONITOR switches to RECORD. 5. Adjust R121 (R221) so that the ripple is minimum.												
24.5μV to MIC MONITOR: MIC	VTVM and 100kΩ resistor in parallel with LINE OUT jack	RECORD	L-CH: L101 1.8/1.45 mH R-CH: L201 See Fig. 4-3-1.	1. Set the MONITOR switches to RECORD. 2. Record an 1 kHz signal of 70 dB. 3. Record a 20 kHz signal of the same level as the one of 1 kHz. Note: Two peaks appear during recording. See Fig. 4-3-4.												
	VTVM to test point (See page 25, TP)	RECORD	at mode                      at mode L-CH: L304      R-CH: L303 See Fig. 4-3-1.	1. Set the REC VOL controls to 100%. 2. Read the VTVM readings on the L-CH and R-CH. 3. Set the machine in L-CH RECORD mode. 4. Adjust L304 so that VTVM reading is 100%. 5. Set the machine in R-CH RECORD mode.												

★ 100kΩ resistor  
 7. Bias voltages across the heads should be read on VTVM as follows.  
 record head: approx. 16 volts at 19 cm/s (7½ ips)  
 14 volts at 9.5 cm/s (3¾ ips)  
 12 volts at 4.8 cm/s (1¾ ips)  
 erase head: approx. 120 volts

Adjust	Procedures and Remarks																								
k head azimuth g screw e Fig. 4-3-3.	Adjust the screw to obtain maximum reading on VTVM.																								
R-CH: R266 (20kΩ; B) R285 (5kΩ; B) e Fig. 4-3-2.	1. Adjust R166 (L-CH) and R266 (R-CH) to obtain 0 dB (0.775V) on VTVM. 2. Adjust R185 (L-CH) and R285 (R-CH) so that pointers of level meters stay at 0 VU (100%).																								
R162 R-CH: R262 2kΩ (B) e Fig. 4-3-2.	Deviation against the level at 400 Hz of 3rd tone <table border="1" data-bbox="397 556 1112 661"> <thead> <tr> <th>Tape tone</th> <th>4th</th> <th>5th</th> <th>6th</th> <th>7th</th> <th>8th</th> </tr> </thead> <tbody> <tr> <td>Frequency</td> <td>12.5 kHz</td> <td>10 kHz</td> <td>7 kHz</td> <td>80 Hz</td> <td>40 Hz</td> </tr> <tr> <td>L-CH</td> <td>0±2 dB</td> <td>0±2 dB</td> <td>0±2 dB</td> <td>+3.0±2 dB</td> <td>+2.0±2 dB</td> </tr> <tr> <td>R-CH</td> <td></td> <td></td> <td></td> <td>+3.5±2 dB</td> <td>+3.0±2 dB</td> </tr> </tbody> </table> After the adjustment, repeat the playback level adjustment.	Tape tone	4th	5th	6th	7th	8th	Frequency	12.5 kHz	10 kHz	7 kHz	80 Hz	40 Hz	L-CH	0±2 dB	0±2 dB	0±2 dB	+3.0±2 dB	+2.0±2 dB	R-CH				+3.5±2 dB	+3.0±2 dB
Tape tone	4th	5th	6th	7th	8th																				
Frequency	12.5 kHz	10 kHz	7 kHz	80 Hz	40 Hz																				
L-CH	0±2 dB	0±2 dB	0±2 dB	+3.0±2 dB	+2.0±2 dB																				
R-CH				+3.5±2 dB	+3.0±2 dB																				
R163 R-CH: R263 3kΩ (B) e Fig. 4-3-2.	Deviation against the level of 400 Hz of 3rd tone <table border="1" data-bbox="397 745 998 850"> <thead> <tr> <th>Tape tone</th> <th>4th</th> <th>5th</th> <th>6th</th> <th>7th</th> </tr> </thead> <tbody> <tr> <td>Frequency</td> <td>5 kHz</td> <td>2.5 kHz</td> <td>200 Hz</td> <td>80 Hz</td> </tr> <tr> <td>L-CH</td> <td>0±2 dB</td> <td>0±2 dB</td> <td>+2±2 dB</td> <td>+0.5±2 dB</td> </tr> <tr> <td>R-CH</td> <td></td> <td></td> <td>+2.5±2 dB</td> <td>+1.0±2 dB</td> </tr> </tbody> </table>	Tape tone	4th	5th	6th	7th	Frequency	5 kHz	2.5 kHz	200 Hz	80 Hz	L-CH	0±2 dB	0±2 dB	+2±2 dB	+0.5±2 dB	R-CH			+2.5±2 dB	+1.0±2 dB				
Tape tone	4th	5th	6th	7th																					
Frequency	5 kHz	2.5 kHz	200 Hz	80 Hz																					
L-CH	0±2 dB	0±2 dB	+2±2 dB	+0.5±2 dB																					
R-CH			+2.5±2 dB	+1.0±2 dB																					
L301 R-CH: L302 1.8 mH e Fig. 4-3-1.	1. Set the REC VOL controls (R135 & R235) to minimum. 2. Adjust to obtain minimum reading on VTVM.																								
head height, zenith and adjusting screw e Fig. 4-3-3.	1. Turn the three screws (height, zenith and azimuth adjusting) so that the record head will be visually horizontal. 2. Set the MONITOR switch to TAPE. 3. Turn the height adjusting screw to obtain maximum reading on VTVM. Memorize the number of turns. 4. Turn the zenith and azimuth adjusting screws the same number of turns of height adjusting screw. 5. Follow the steps 3 and 4 to obtain maximum reading.																								
head azimuth adjusting e Fig. 4-3-3.	1. Set the MONITOR switch to TAPE position. 2. Turn the azimuth adjusting screw to obtain maximum reading on VTVM. Within one turn of the screw, the maximum reading should be obtained. If not, repeat the adjustment as in the item 5.																								
C603 R-CH: C604 30-200pF e Fig. 4-3-1.	1. Set the MONITOR switch to TAPE position. 2. Turn the trimmer capacitors counterclockwise and set them in minimum capacitance position. 3. Recording the signal, turn the trimmer capacitor (C603, L-CH) clockwise slowly until the VTVM reads the maximum value. 4. Continue to turn the capacitor until the VTVM reads a value 0.5 dB below the maximum reading. Read the VTVM reading. 5. Adjust the trimmer capacitor (C604, R-CH) in the same way. 6. Make sure that the reading of L-CH is the same as the one reading in the step 4. 7. If not, follow the steps 2-6 again.																								
R121 R-CH: R221 5kΩ (B) e Fig. 4-3-1.	1. Set the MONITOR switches (S105 & S205) to SOURCE position. 2. Feeding the signal, slide the REC VOL controls (R135 & R235) so that the level meters indicate 0 VU (100%). 3. Record the signal on a blank tape. 4. Set the MONITOR switches (S105 & S205) to TAPE position. 5. Adjust R121 (R221) so that VTVM indicates 0 dB (0.775V).																								
L101 R-CH: L201 1.8/1.45 mH e Fig. 4-3-1.	1. Set the MONITOR switches (S105 & S205) to TAPE position. 2. Record an 1 kHz signal of -90 dB (24.5μV) on a blank tape and read the VTVM reading. 3. Record a 20 kHz signal of -90 dB (24.5μV) and adjust L101 (L201) so that VTVM reading is the same as the one of 1 kHz signal. Note: Two peaks appear during turning L101 (L201). Take the peak where the core is "b" position shown in Fig. 4-3-4.																								
e at mode L304 R-CH: L303 See Fig. 4-3-1.	1. Set the REC VOL controls (R135 & R235) to minimum. 2. Read the VTVM readings of both channels. 3. Set the machine in L-CH RECORD mode. 4. Adjust L304 so that VTVM reading is the same as the one reading in the step 2. 5. Set the machine in R-CH RECORD mode and adjust L303 in the same way.																								



5-2. WIRING DIAGRAM (USA, Canada)

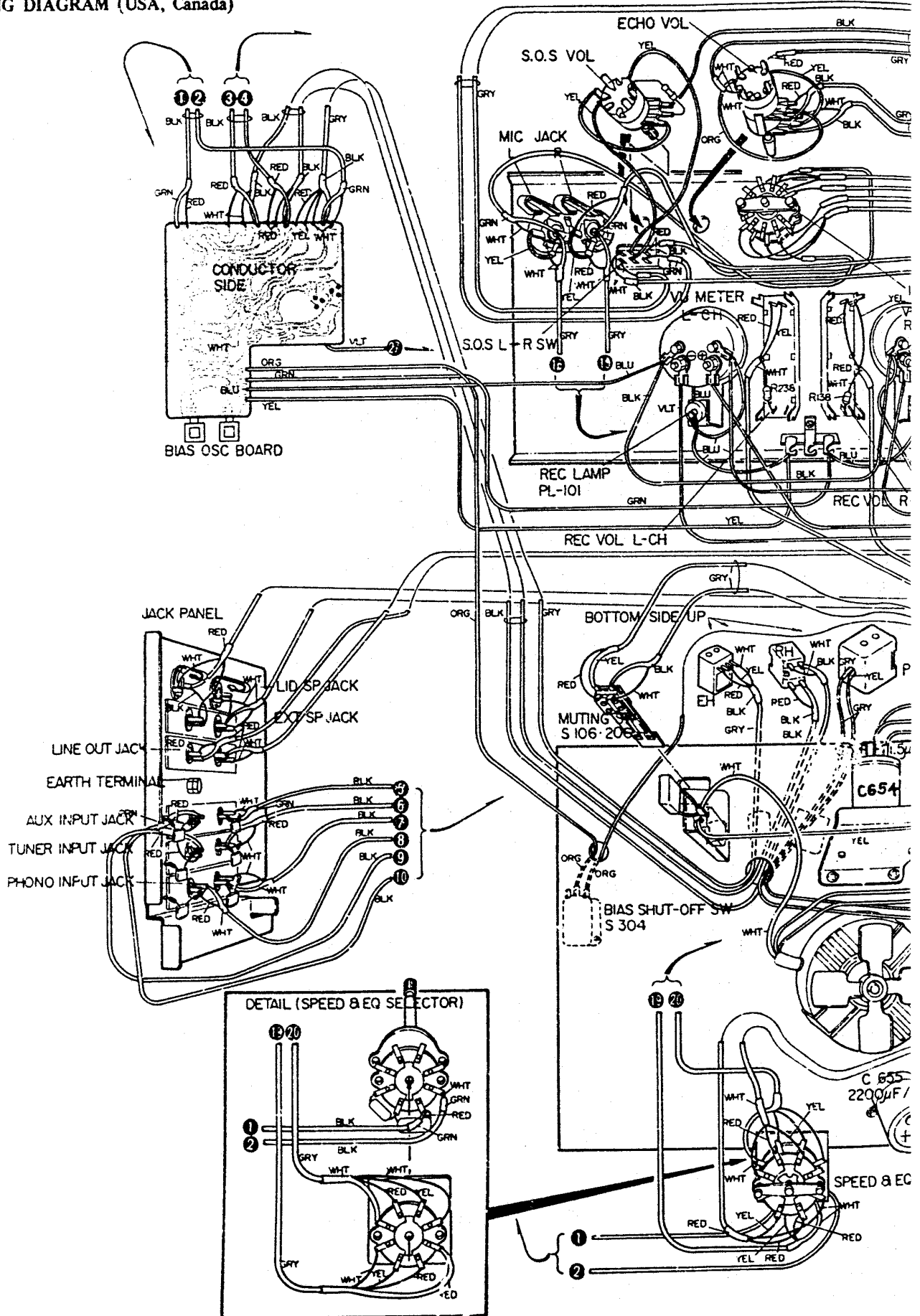



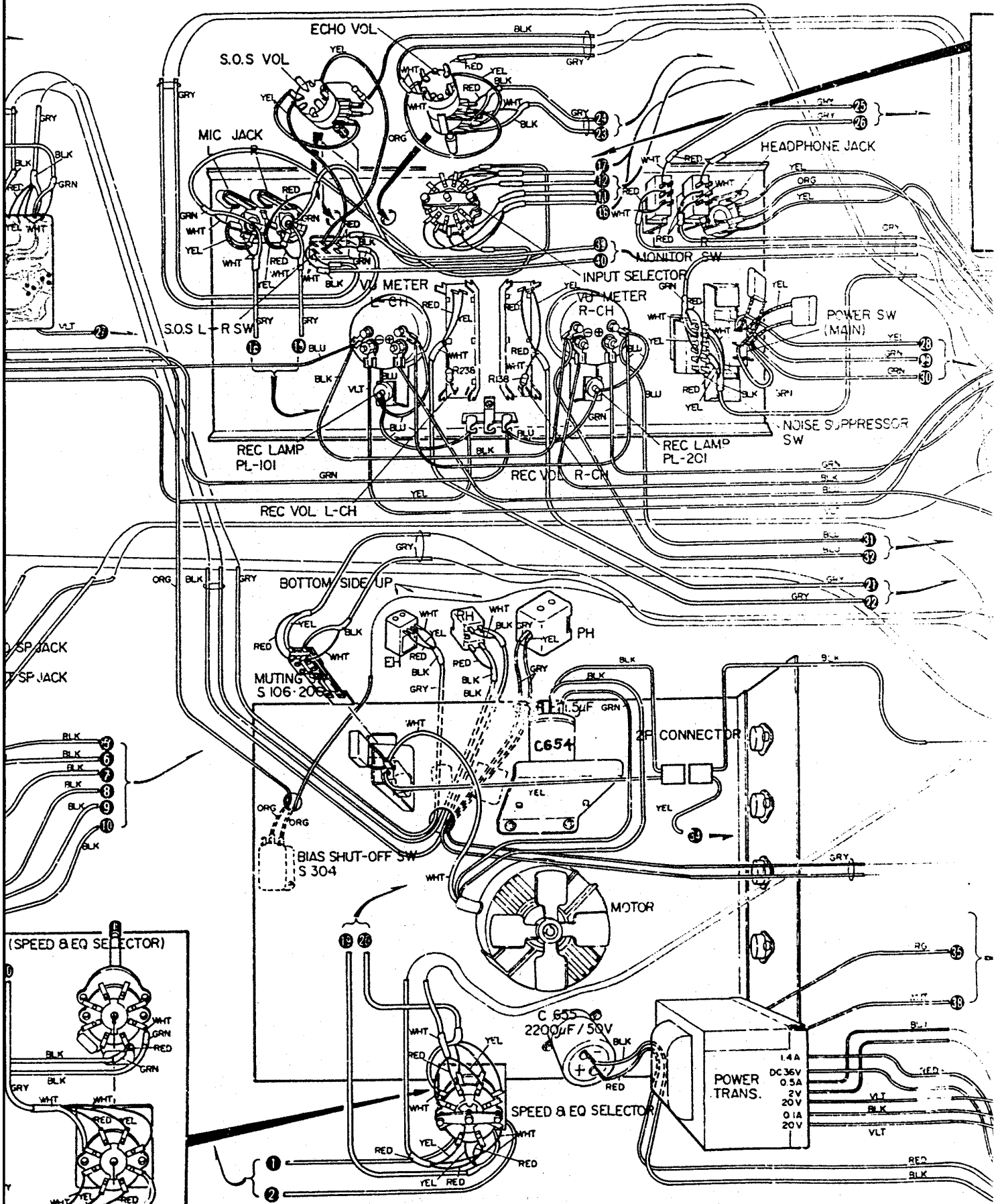

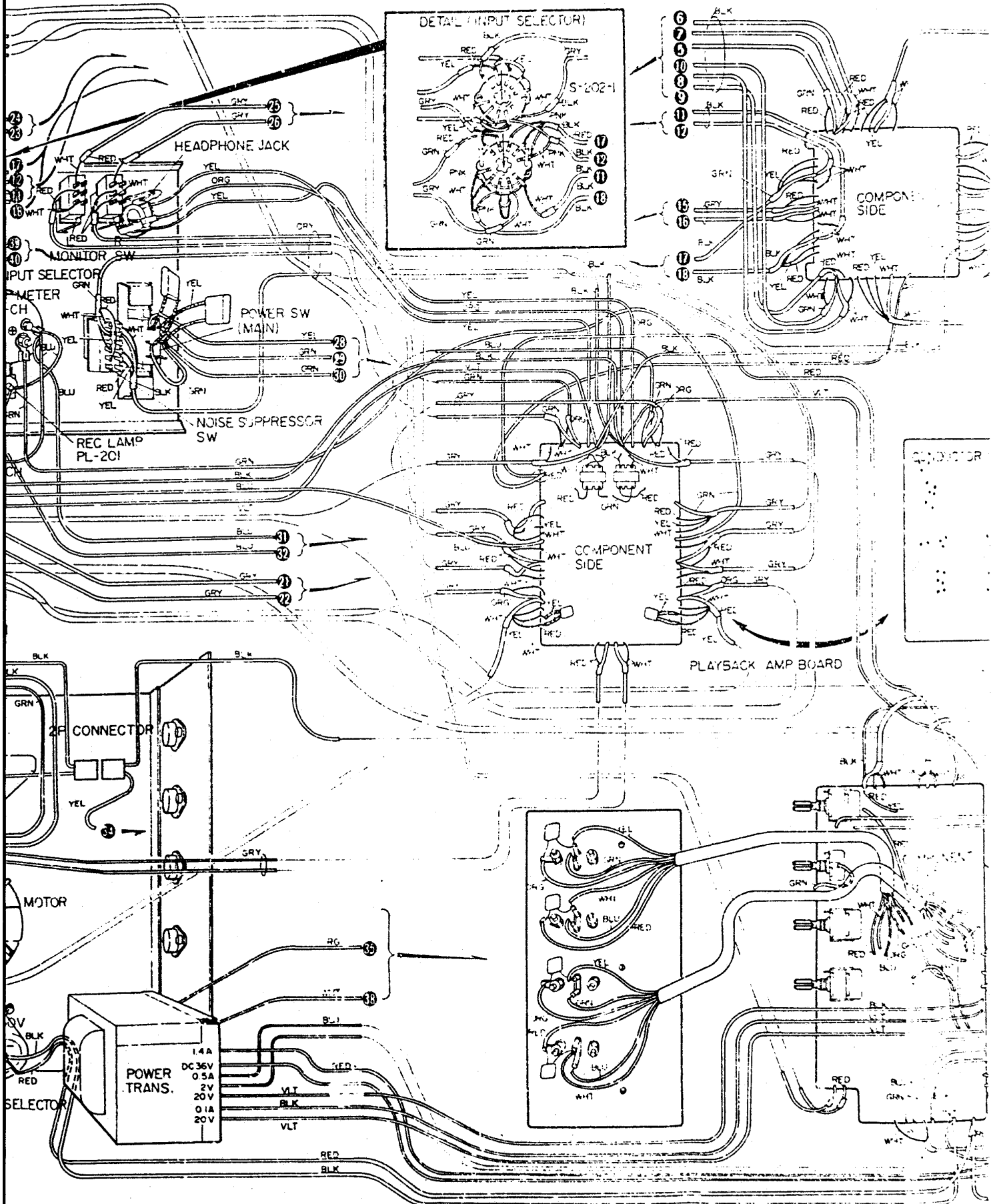







5.3. MOUNTING DIAGRAMS  
 Record Amp Circuit Board  
 - Conductor Side -

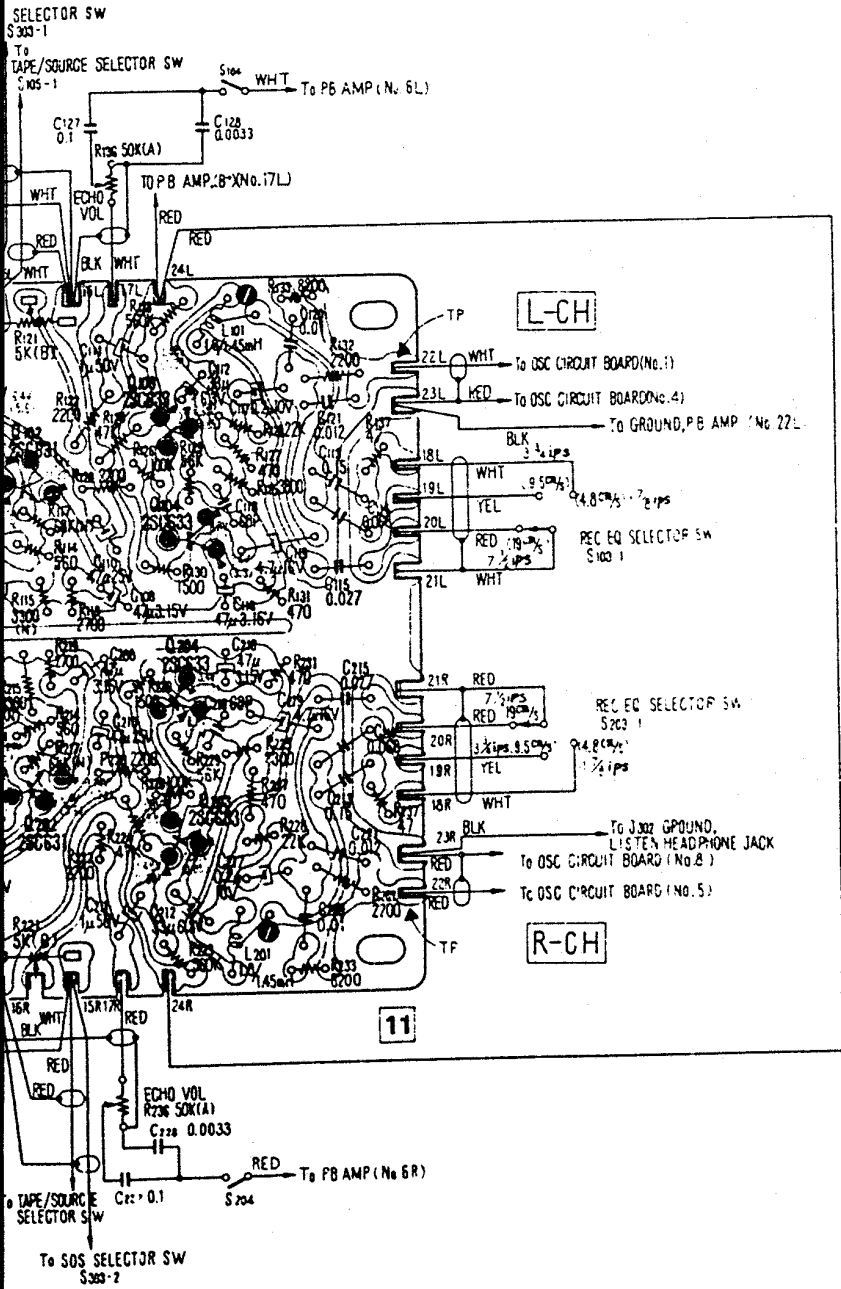

TC-630

Trap & Dummy Coil Circuit Board  
 - Conductor Side -

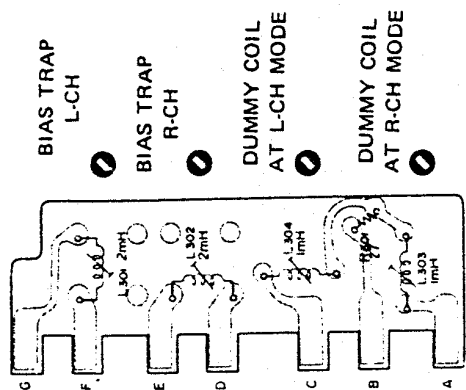

11

printed circuit board  
 part no. I-539-017-11

Bias Osc Circuit Board  
 - Conductor Side -

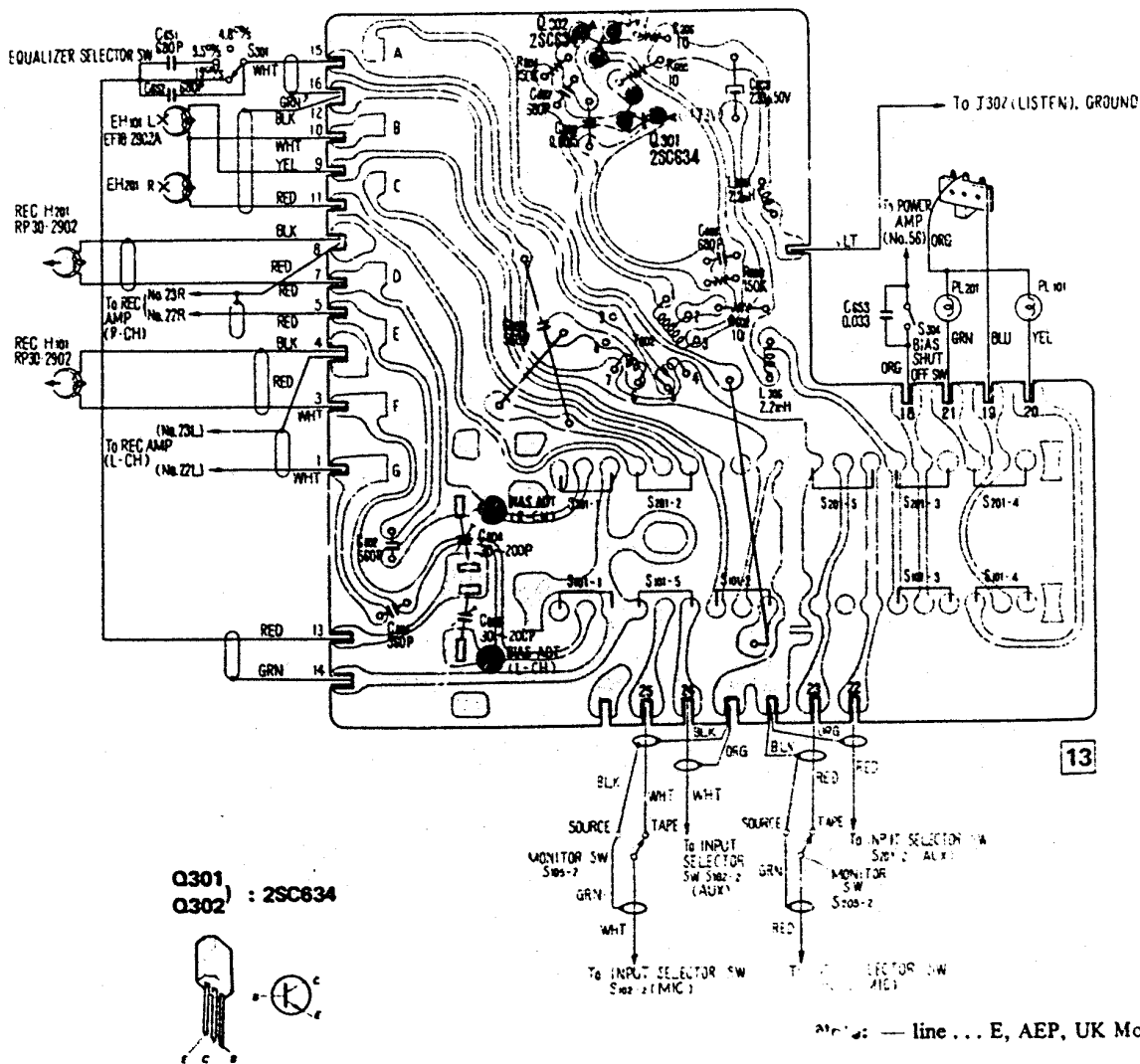

13

Q301 : 2SC634  
 Q302 : 2SC634

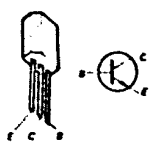

Notes: — line ... E, AEP, UK Model

- Q105
- Q205
- Q106 :25C671
- Q206
- Q107
- Q207
- Q108, 208
- Q109, 209 :25C633
- Q110, 210

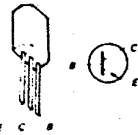

- 27 -

D101, 201: 1T22

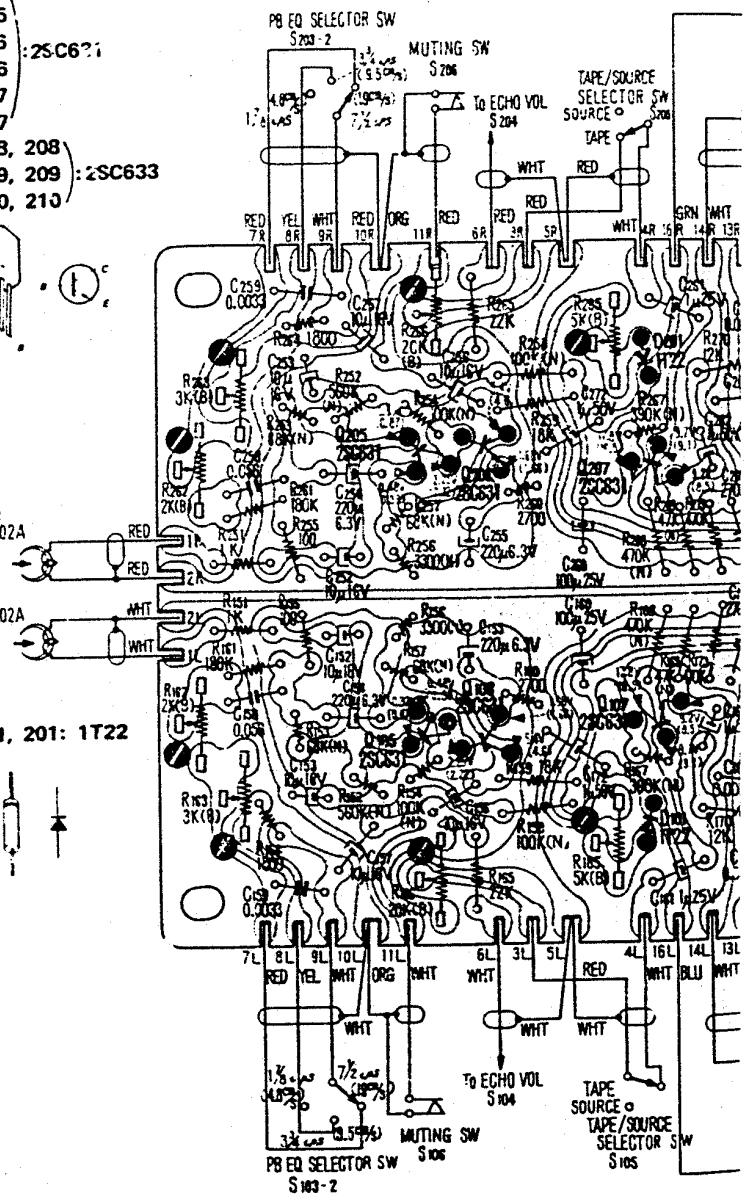

For Service Manuals  
**MAURITRON SERVICES**  
 8 Cherry Tree Road, Chinnor  
 Oxfordshire, OX9 4QY.  
 Tel (01844) 351894  
 Fax (01844) 352554  
 email: mauritron@dial.pipex.com



- Q105
- Q205
- Q106 : 2SC671
- Q206
- Q107
- Q207
- Q108, 208
- Q109, 209 : 2SC633
- Q110, 210

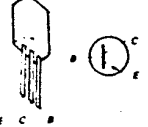

- 27 -

P8H 201  
PP30-2902A

P8H 101  
PP30-2902A

D101, 201: 1T22

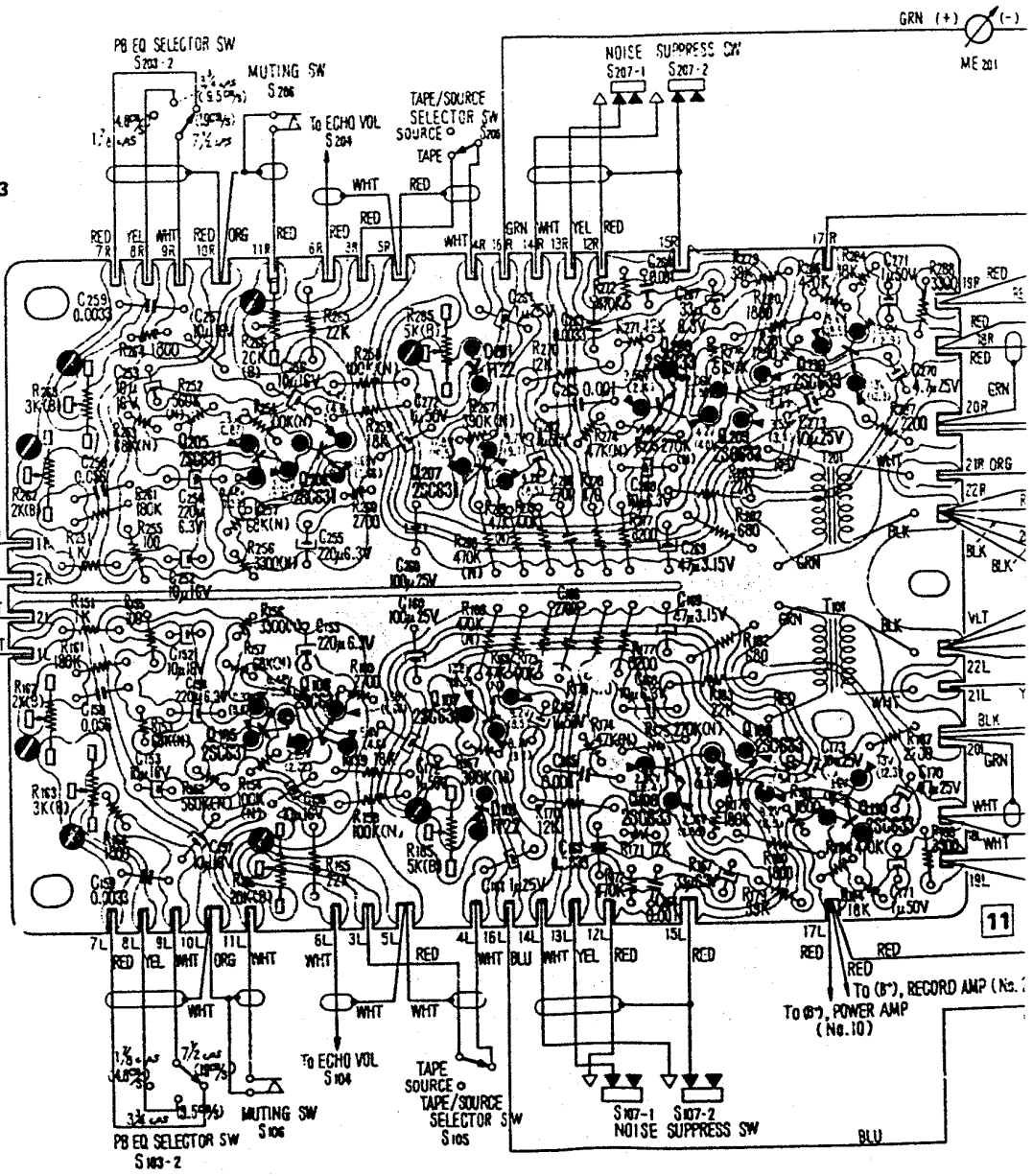
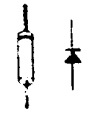

GRN (+) (-)  
ME 201

11

Playback Amp Circuit Board  
 - Conductor Side -

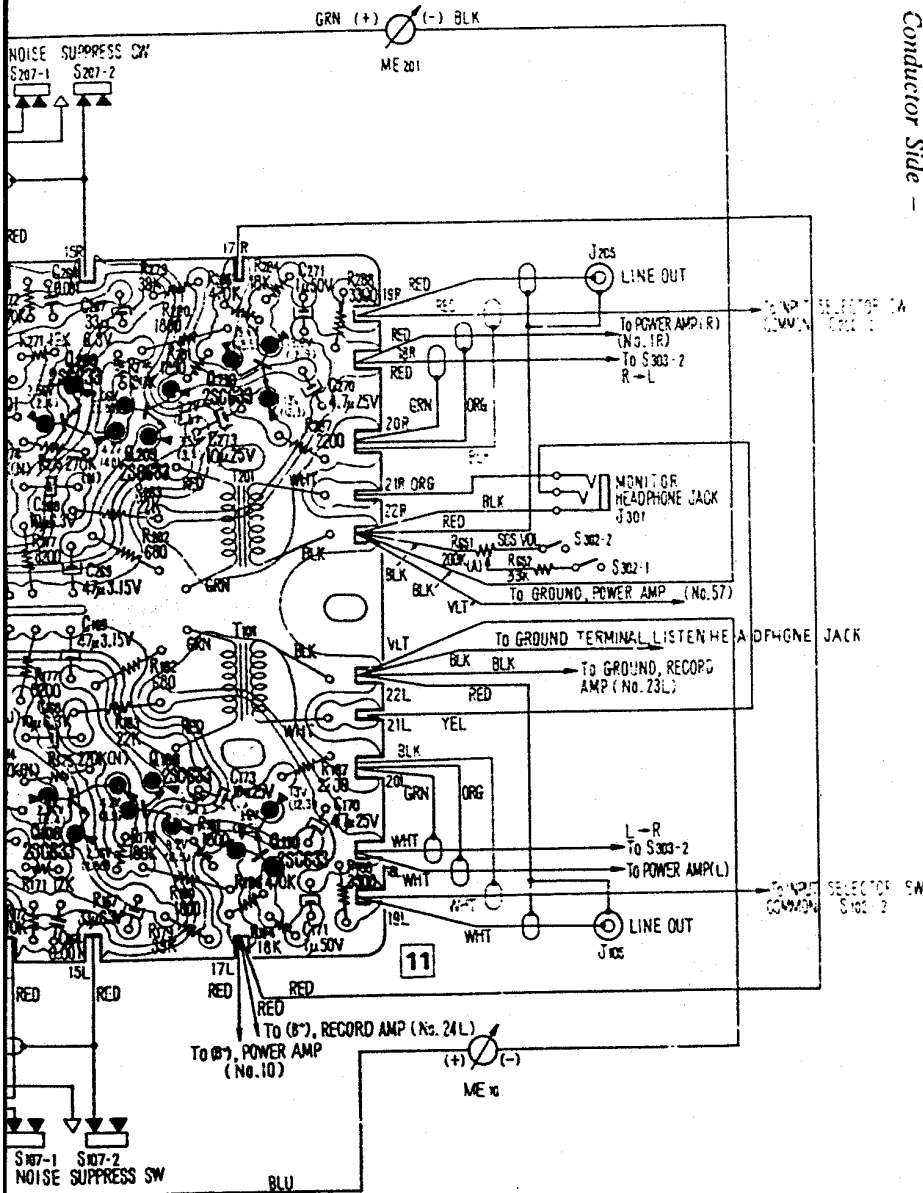

Note: — line ... F. AEP, UK Model

TC-630



To L10/EXT SP SELECTOR SW

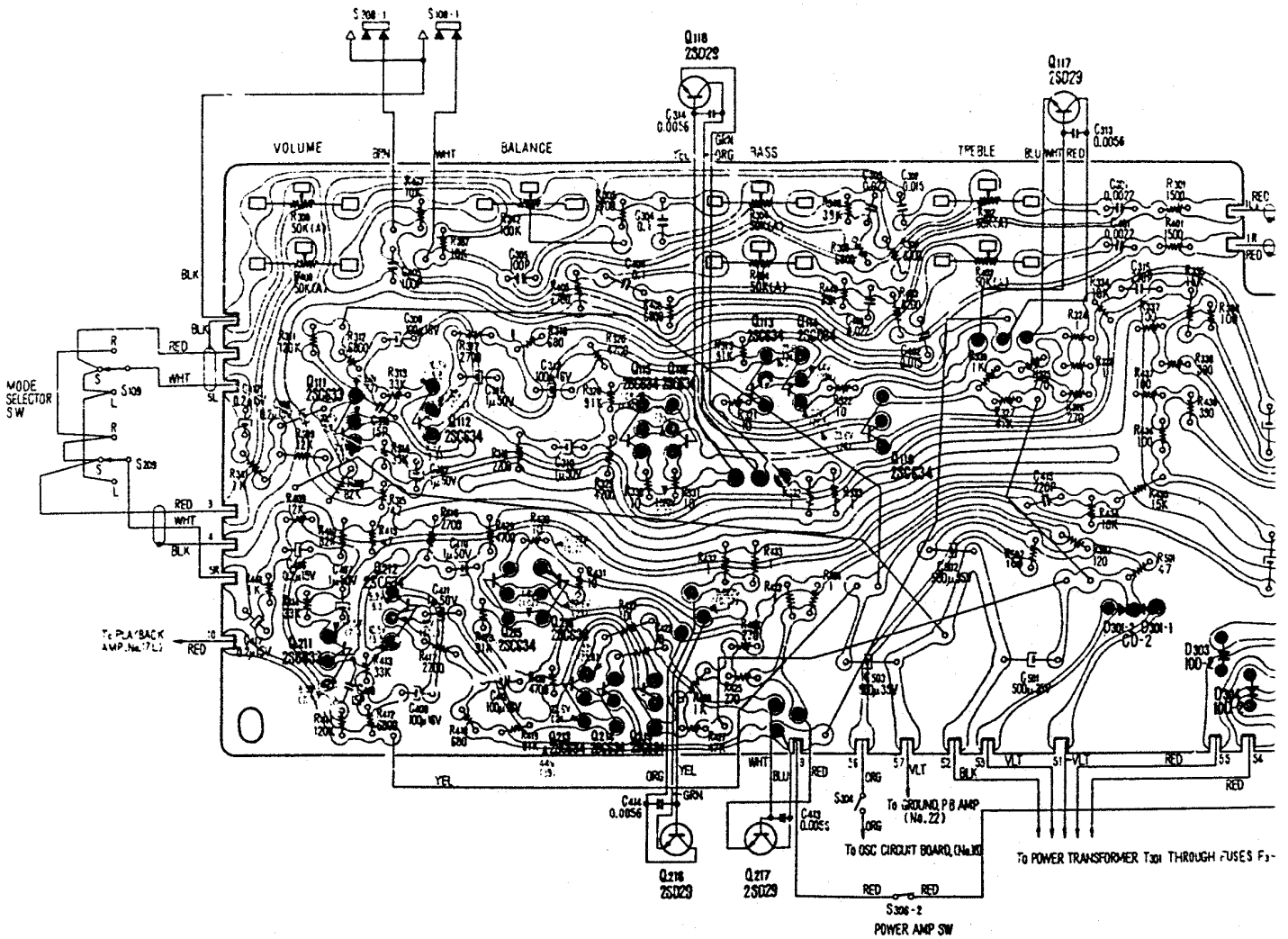

- Q111, 211 : 2SC633
- Q112, 212
- Q113, 213
- Q114, 214
- Q115, 215
- Q116, 216
- Q119, 219

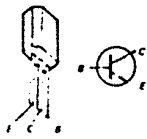

- Q117, 217
- Q118, 218 : 2SC895

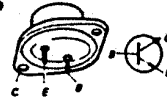

- D301: CD-2



- D302
- D303 : 10D
- D304
- D305

TC-630

Power Amp Circuit Board  
- Conductor Side -

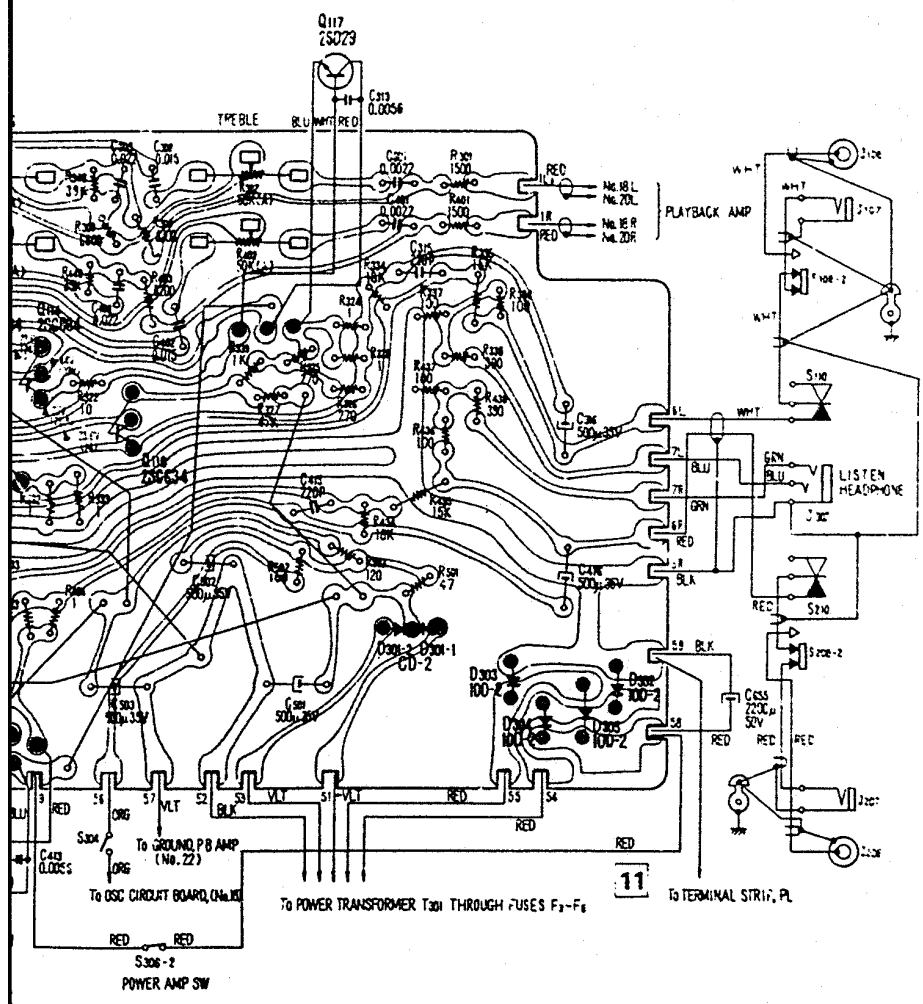

D301: CD-2

D302  
D303 : 10D-2  
D304  
D305

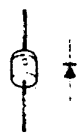
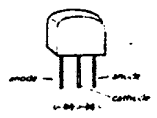
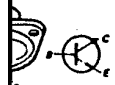

5-4. SCHEMATIC DIAGRAM

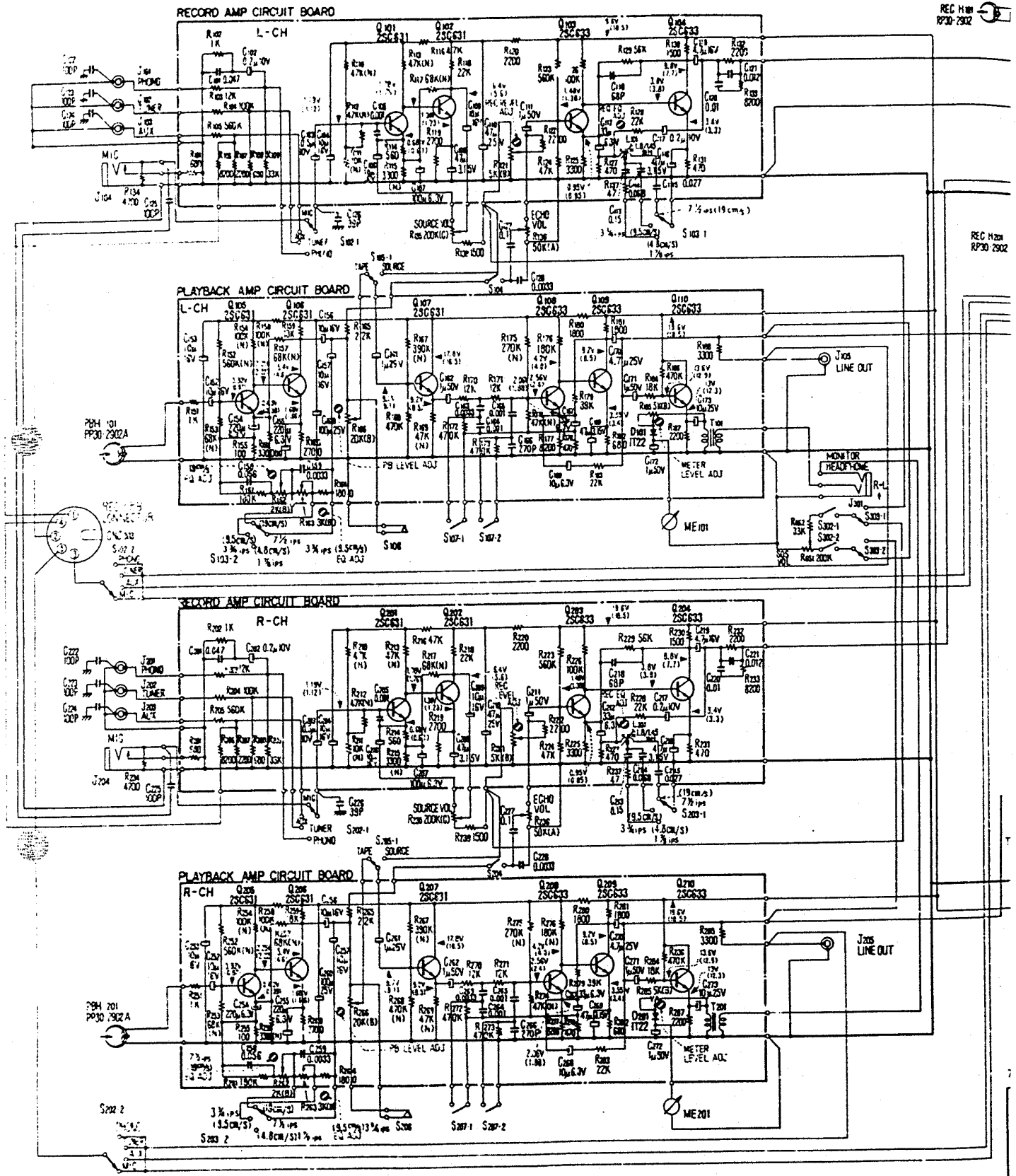

Notes:

1. : adjustable
2. : grounded to chassis
3. All resistors and capacitors are rated in  $\Omega$  and  $\mu F$  respectively unless otherwise specified.
4. Resistor whose rating value is suffixed with the letter (N) is low-noise resistor.
5. The letter (A), (B) or (C) suffixed to rating value of variable resistor indicates its characteristic.
6. Voltage values are measured to ground with a VTVM in PLAYBACK and RECORD modes at the speed of 7% ips (19 cm/s). Variations may be noted due to normal production tolerances. Voltage values in RECORD mode are in parenthesis.

# TC-630 TC-630

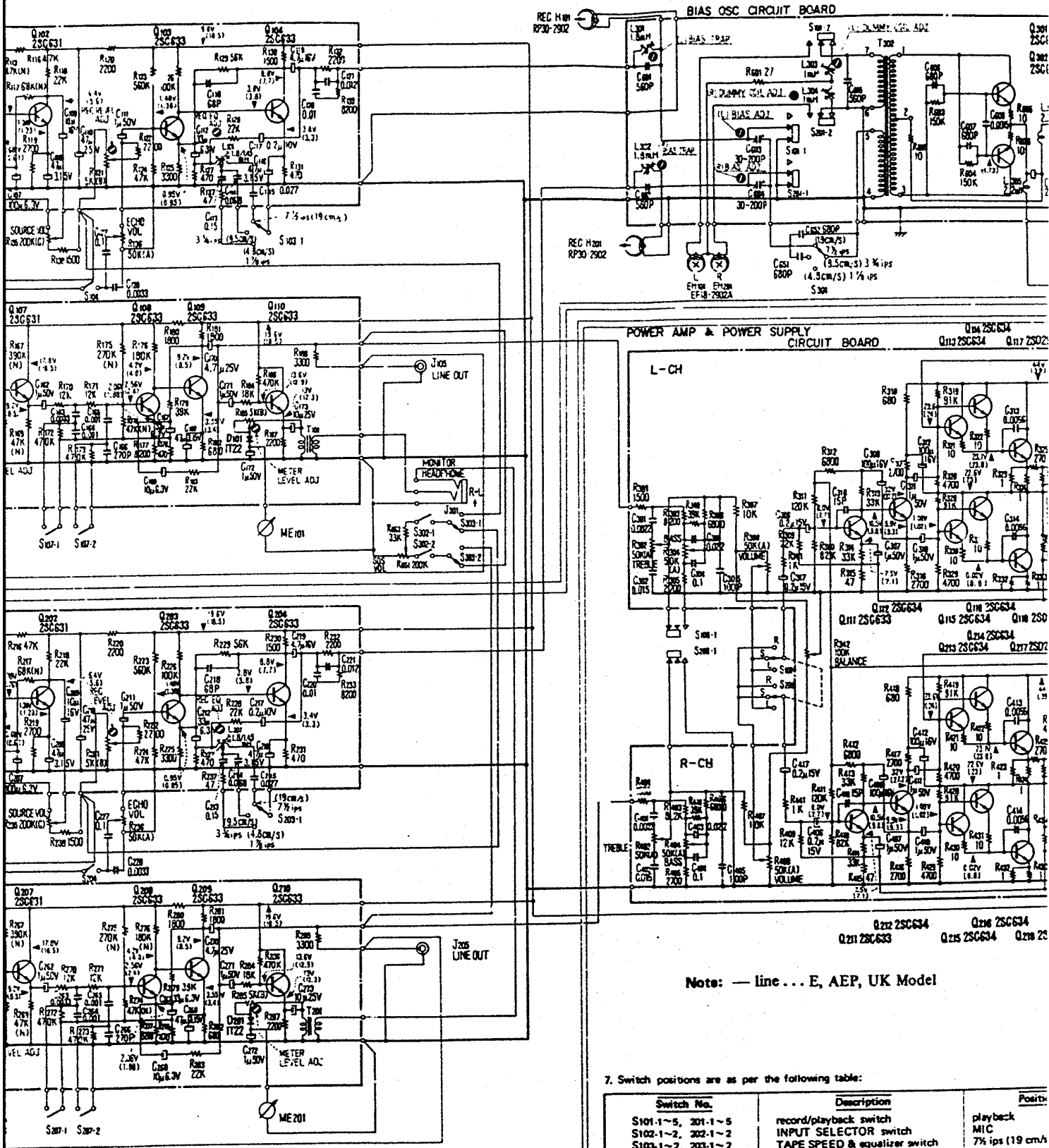

Note: — line . . . E, AEP, UK Model

7. Switch positions are as per the following table:

Switch No.	Description	Position
S101-1~5, 201-1~5	record/playback switch	playback
S102-1~2, 202-1~2	INPUT SELECTOR switch	MIC
S103-1~2, 203-1~2	TAPE SPEED & equalizer switch	7 1/2 ips (19 cm/s)
J104, 204	ECHO switch	OFF
S105-1~2, 205-1~2	MONITOR switch	TAPE
S106, 206	muting switch	OFF
S107-1~2, 207-1~2	NOISE SUPPRESS switch	OFF
S108-1~2, 208-1~2	SPEAKER SELECTOR switch	LID
S108, 208	MODE selector switch	STEREO
S110, 210	HEADPHONE & speaker switch	speaker
S301	SPEED & equalizer switch	7 1/2 ips (19 cm/s)
S302-1, 302-2	SOS switch	OFF
S303-1, 303-2	SOS selector switch	L → R
S304	bias shut-off switch	ON(E,AEP,UK)
S305-1, 305-2	POWER switch	ON(E,AEP,UK)
S306-1, 306-2	POWER AMP switch	ON(E,AEP,UK)
S307	auto-shut-off switch	ON(E,AEP,UK)
S308	frequency selector switch	60Hz

5. The letter (A), (B) or (C) suffixed to rating value of variable resistor indicates its characteristic.

6. Voltage values are measured to ground with a VTVM in PLAYBACK and RECORD modes at the speed of 7 1/2 ips (19 cm/s). Variations may be noted due to normal production tolerances. Voltage values in RECORD mode are in parenthesis.

7. Values are rated in Ω and μF respectively.

8. Value is suffixed with the letter (N)





5-5. LEVEL DIAGRAMS

**PLAYBACK**

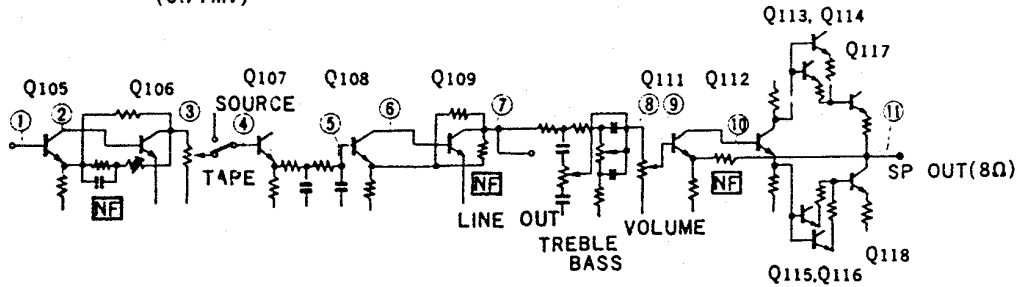
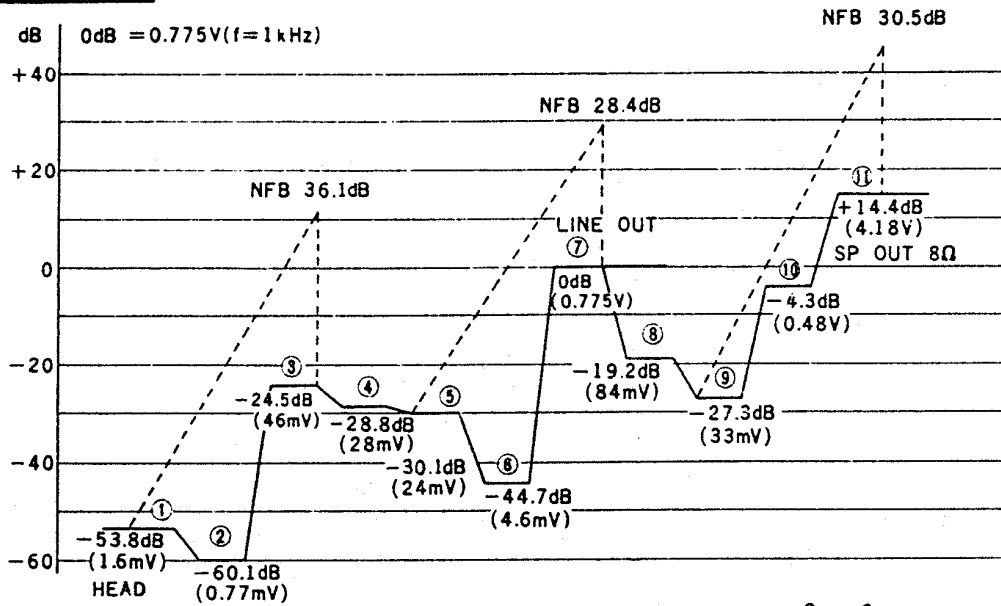

**RECORD**

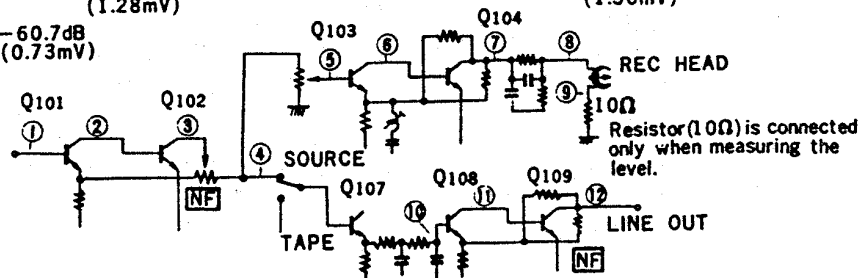
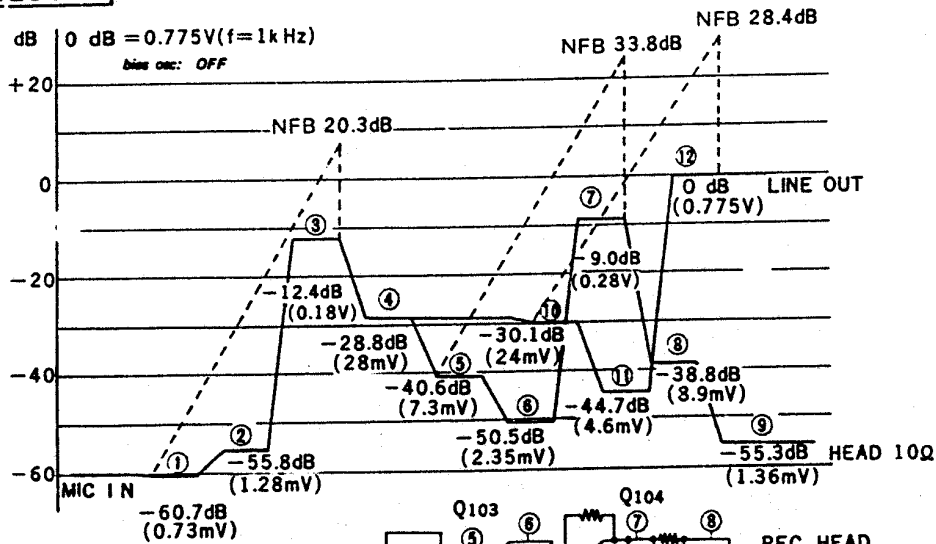

## SECTION 6 EXPLODED VIEWS

### 6-1. CONTROL CHASSIS - Top View -

**Note:** Parts without part numbers and names are not available.

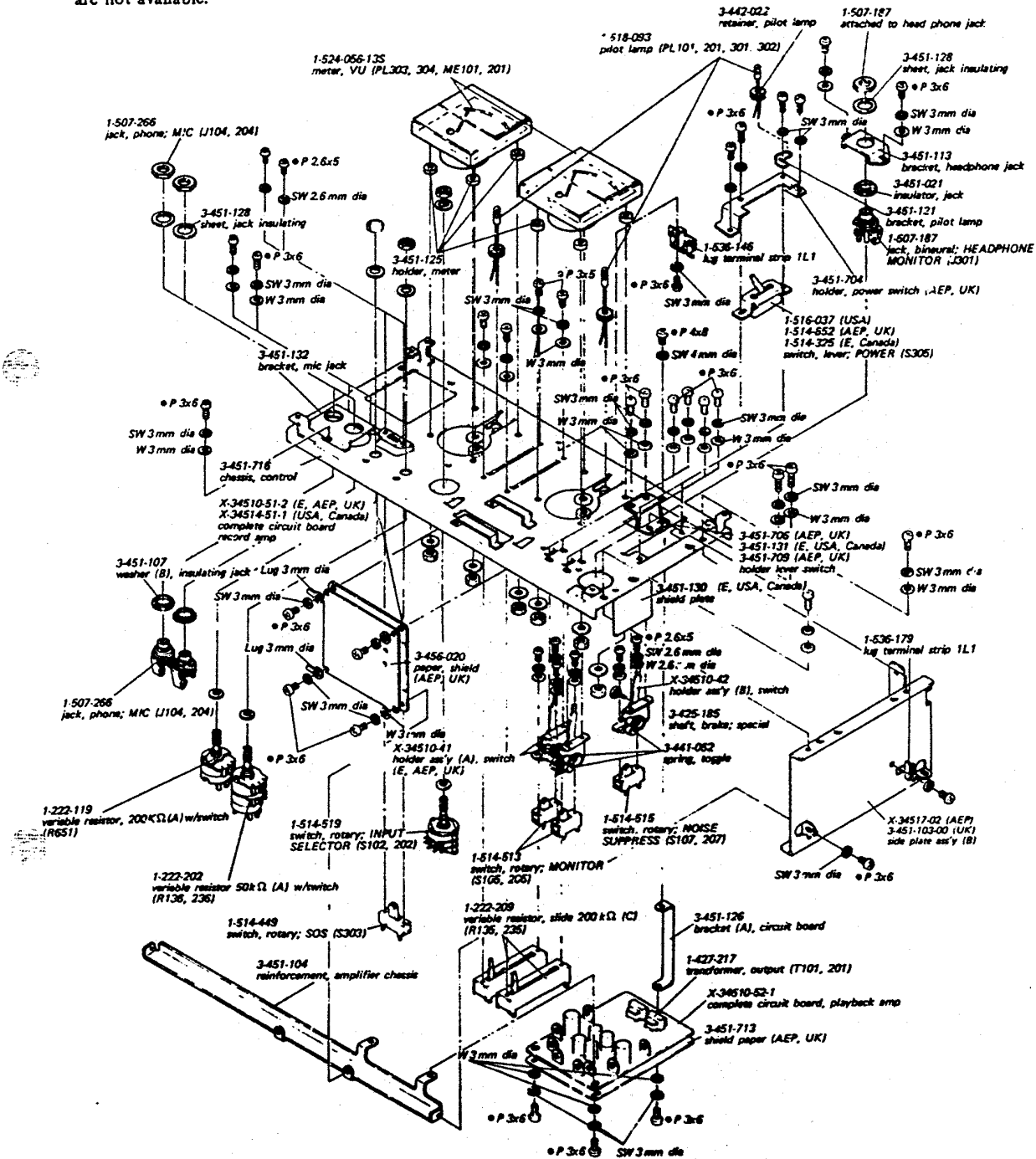



6-3. AMP CHASSIS - Top View -

Note: Parts without part numbers and names are not available.

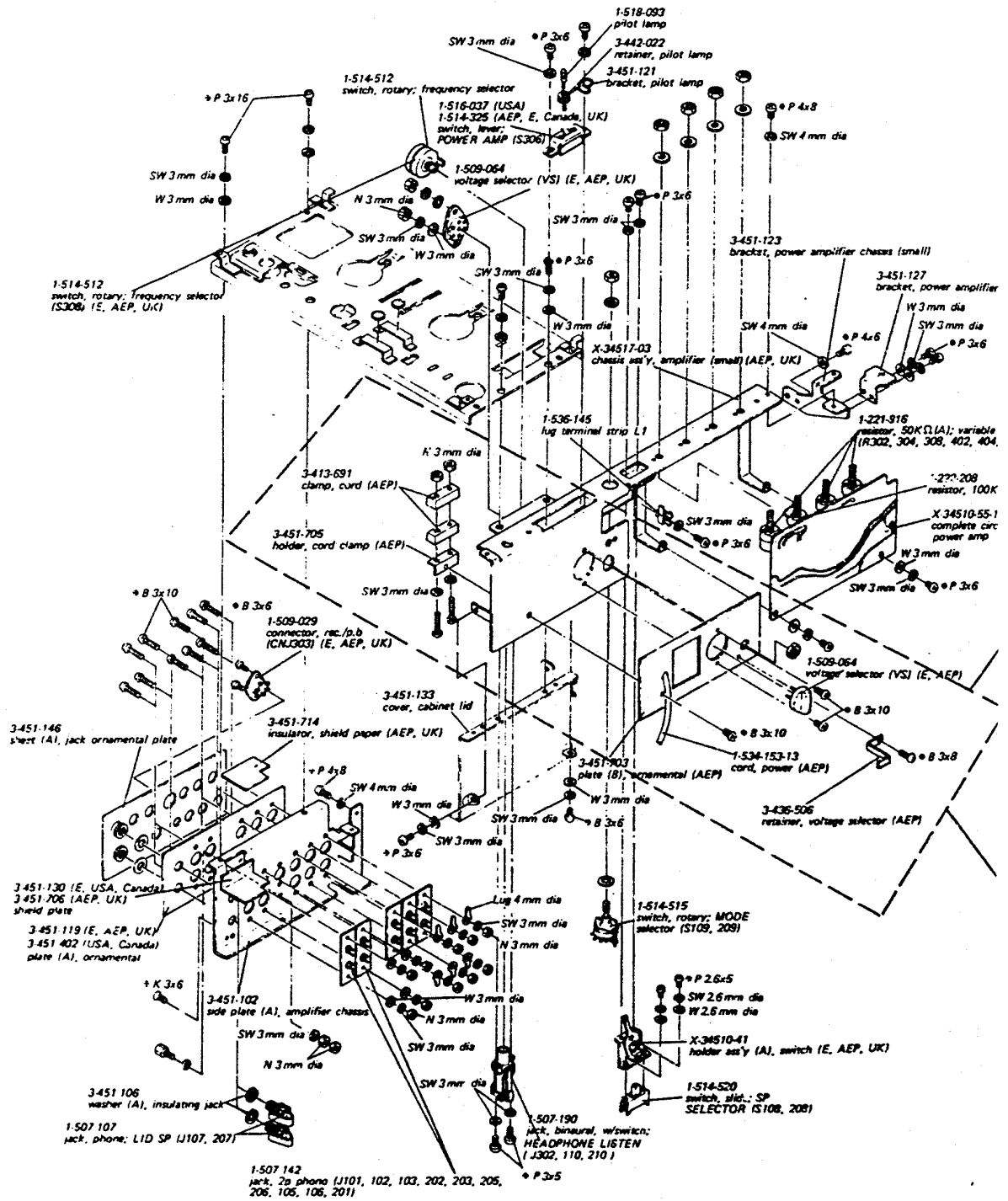

mes

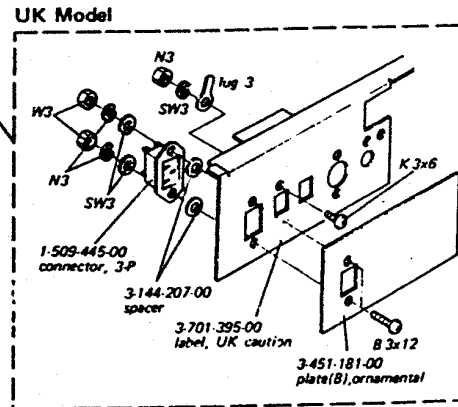
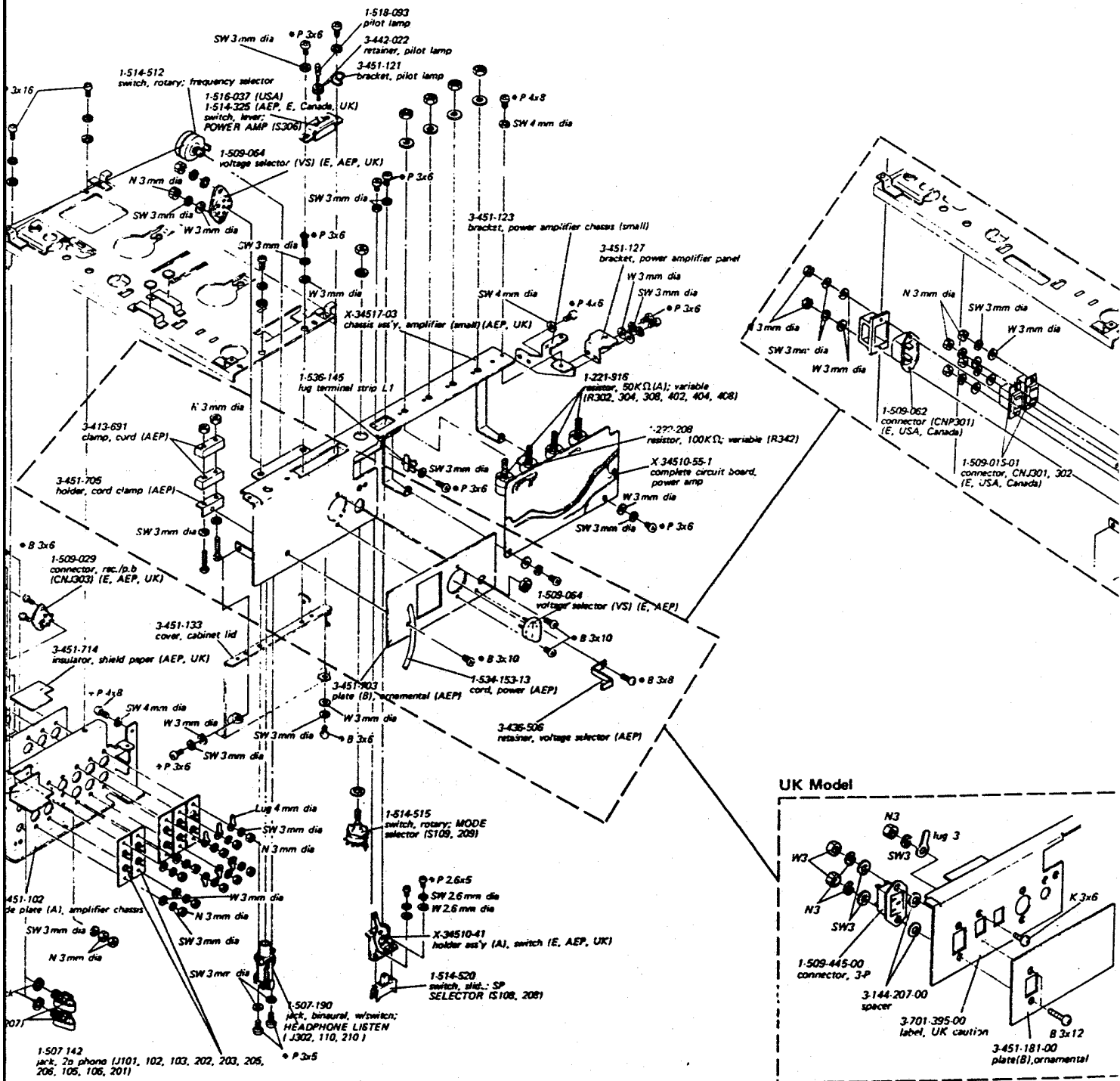

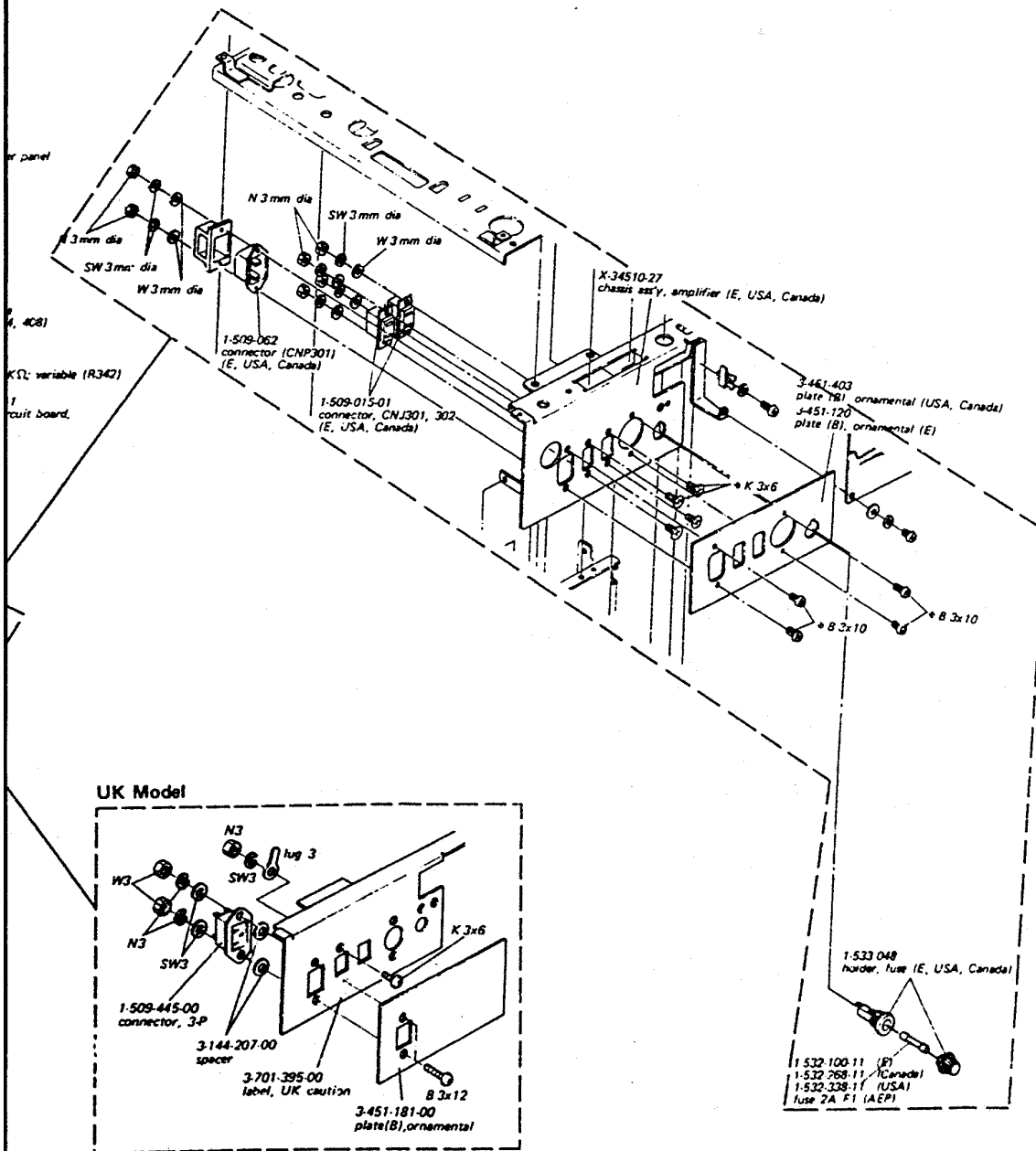

UK Model

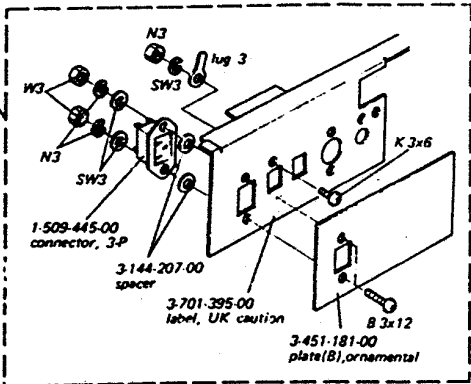

For Service Manuals  
**MAURITRON SERVICES**  
 8 Cherry Tree Road, Chinnor  
 Oxfordshire, OX9 4QY.  
 Tel (01844) 351694  
 Fax (01844) 362664  
 email:- mauritron@dial.pipex.com



**6-5. HEAD DECK - Top View -**

Note: Parts without part numbers and names are not available.

(Serial No. 124,701 and later)

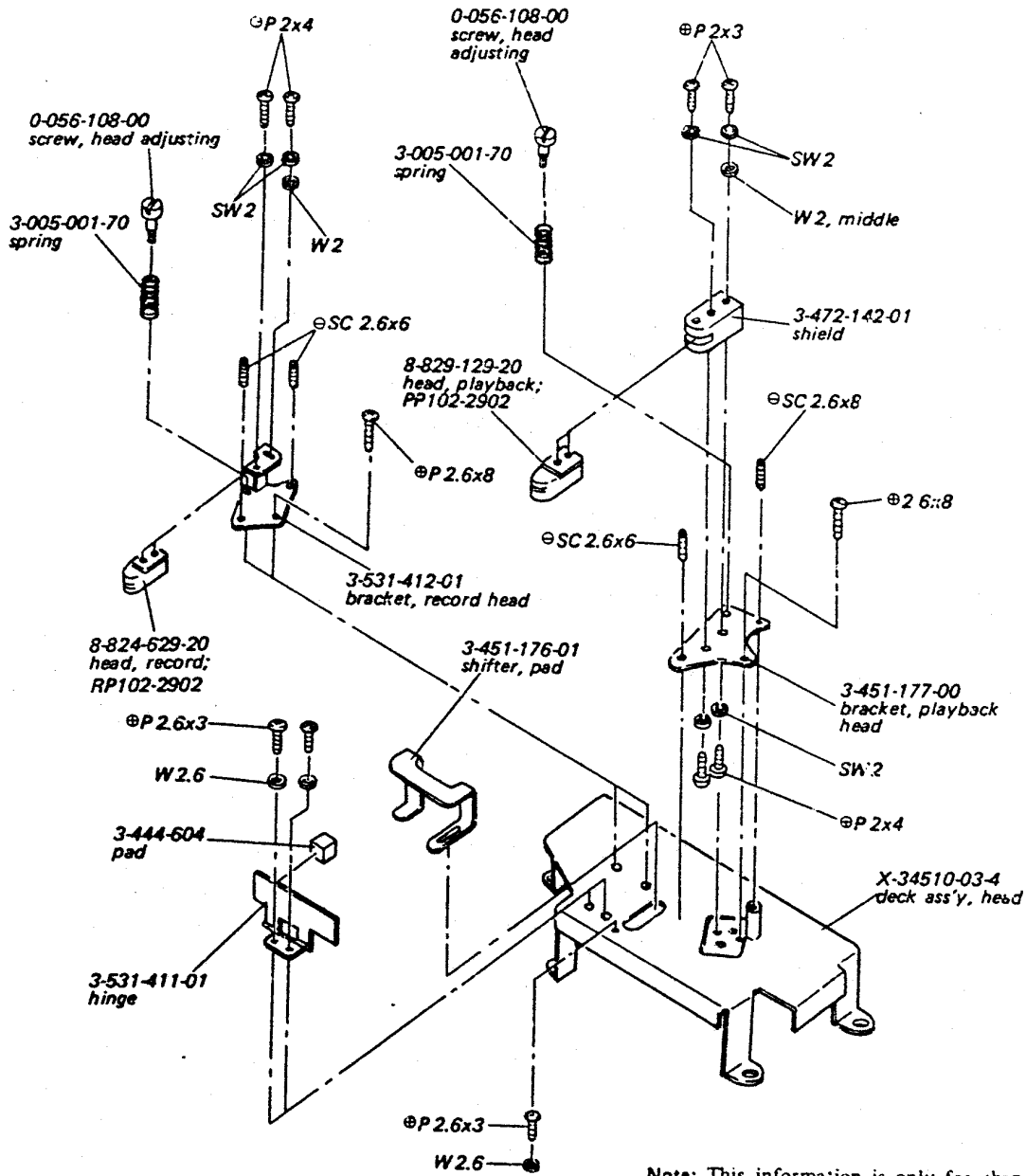

Note: This information is only for changed parts of Serial No. 124,701 and later. See page 37 for other information.







6-6. CHASSIS -- Top View --  
 Note: Parts without part numbers and names are not available.

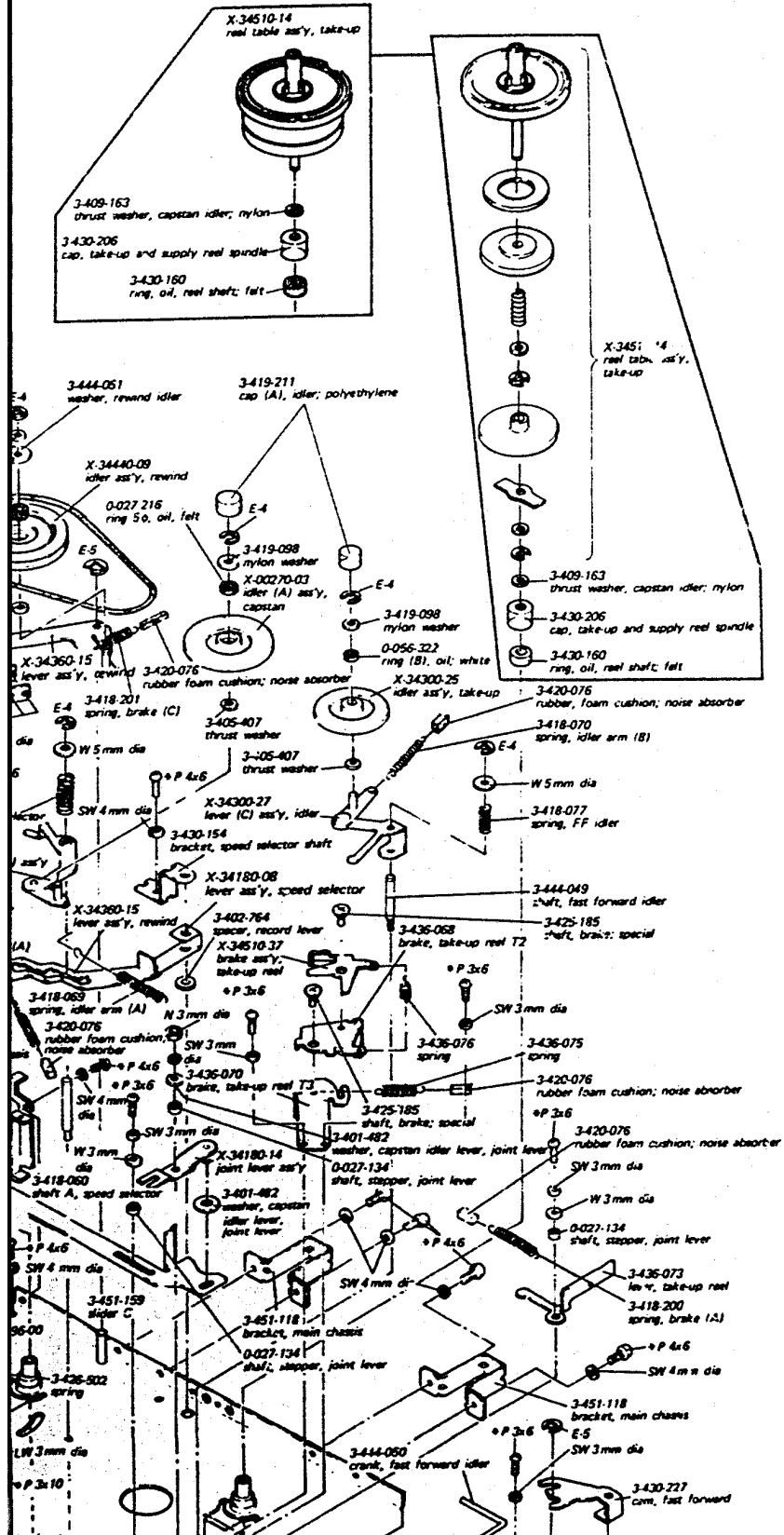

TC-630 TC-630





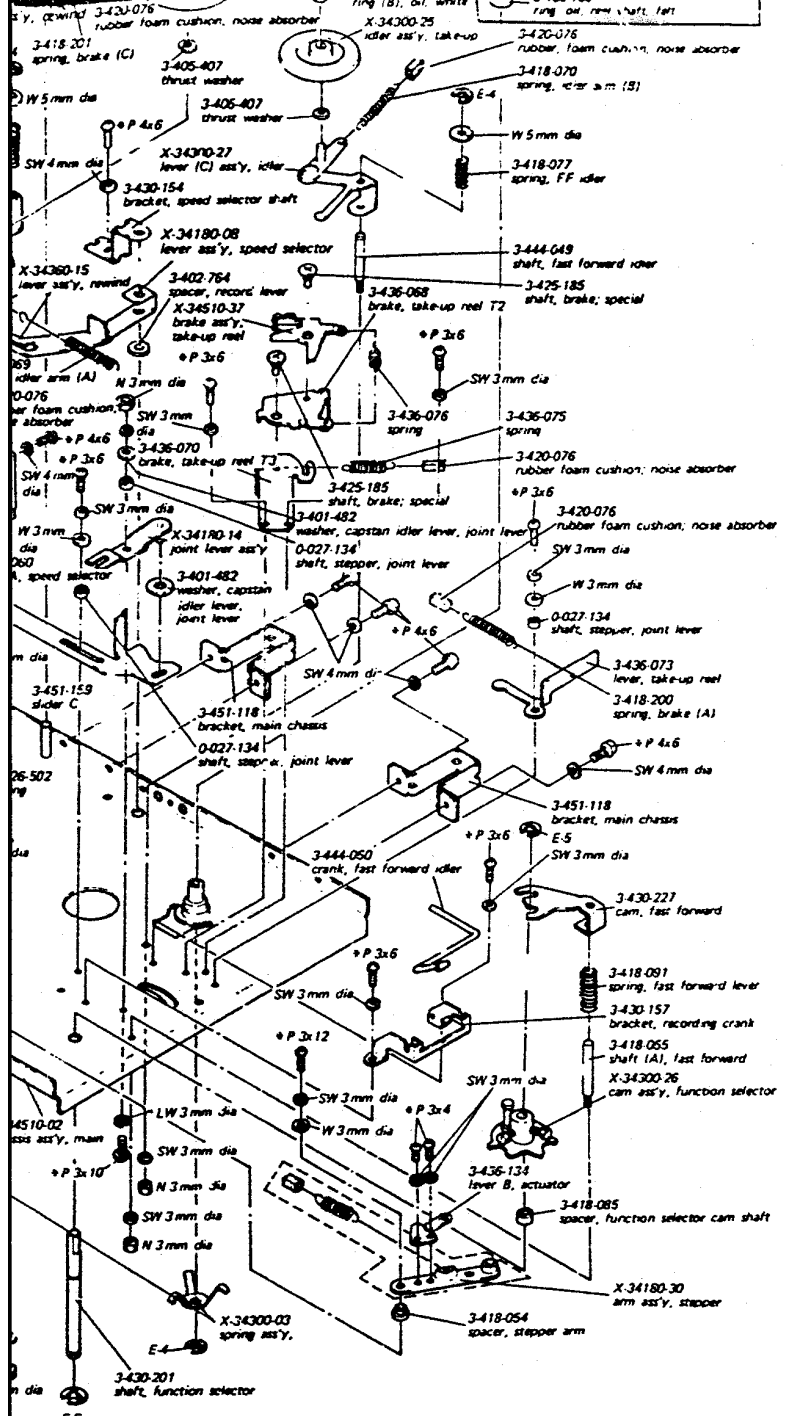

**TC-630 TC-630**

### 6-8. SPEAKER BOX - Top View -

Note: Parts without part numbers and names are not available.

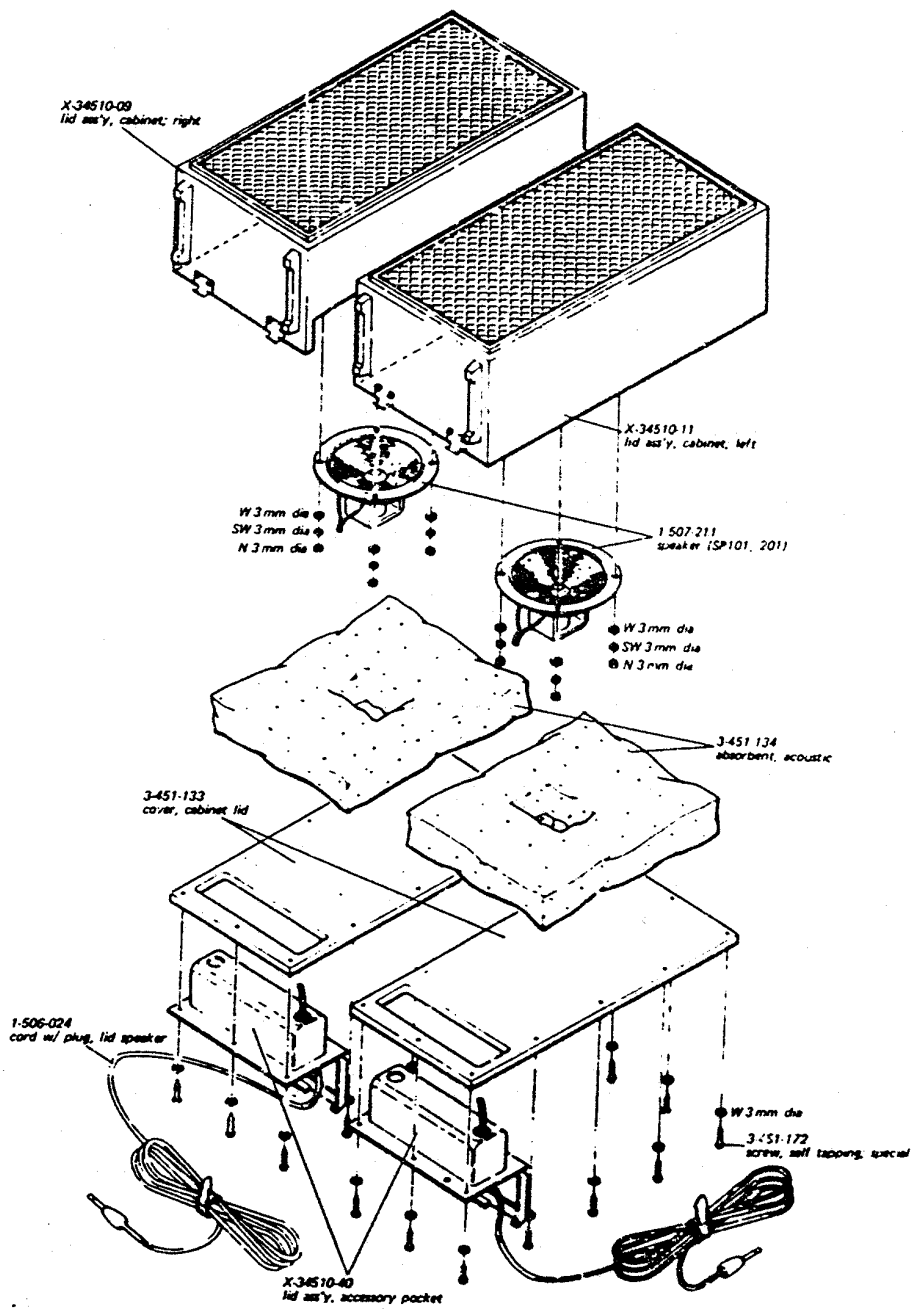

### ACCESSORIES & PACKING

3-430-229-03	cap, reel	3-793-636-81	leaflet, tape talk (UK)
3-790-272-05	manual, instruction (E, AEP)	8-811-260-10	microphone, F-26
3-790-272-26	manual, instruction (USA)	8-918-210-71	tape, demonstration DSE-721 (E, AEP, Canada, UK)
3-790-272-44	manual, instruction (Canada)	X-34510-34-6	carton ass'y (E, AEP, Canada)
3-790-272-81	manual, instruction (UK)	X-34510-34-7	carton ass'y (USA)
3-793-010-20	leaflet, tape talk (E, AEP, Canada, USA)	X-37010-18-2	cleaning tip (E, AEP, Canada)

## SECTION 7 ELECTRICAL PARTS LIST

<u>Ref. No.</u>	<u>Part No.</u>	<u>Description</u>
<b>COMPLETE CIRCUIT BOARDS</b>		
X-34514-51-1		record amp (USA, Canada)
X-34510-51-2		record amp (E, AEP, UK)
X-34510-52-1		playback amp
X-34510-55-1		power amp
X-34514-52-1		bias osc (USA, Canada)
X-34510-53-1		bias osc (E, AEP, UK)
X-34510-54-1		trap coil

<u>Ref. No.</u>	<u>Part No.</u>	<u>Description</u>
T101, 201	1-427-217-12	transformer, output
T301	1-441-450-16	transformr, power (E)
	1-441-460-14	transformer, power (Canada)
T301	1-442-025-11	transformer, power (USA)
	1-441-555-12	transformer, power (AEP, UK)
T302	1-433-133-11	transformer, bias osc
T401	1-441-370-11	transformer, motor (AEP, UK)

**SEMICONDUCTORS**

Q101, 201	transistor	2SC631
Q102, 202	transistor	2SC631
Q103, 203	transistor	2SC633
Q104, 204	transistor	2SC633
Q105, 205	transistor	2SC631
Q106, 206	transistor	2SC631
Q107, 207	transistor	2SC631
Q108, 208	transistor	2SC633
Q109, 209	transistor	2SC633
Q110, 210	transistor	2SC633
Q111, 211	transistor	2SC633
Q112, 212	transistor	2SC634
Q113, 213	transistor	2SC634
Q114, 214	transistor	2SC634
Q115, 215	transistor	2SC634
Q116, 216	transistor	2SC634
Q117, 217	transistor	2SC895
Q118, 218	transistor	2SC895
Q119, 219	transistor	2SC634
Q301, 302	transistor	2SC634
D101, 201	diode	1T22
D301	diode	CD-2
D302, 303	diode	10D-2
D304, 305	diode	10D-2

**COILS & TRANSFORMERS**

L101, 201	1-231-069	coil, equalizer 1.45 mH/1.8 mH
L301, 302	1-409-141	coil, trap 1.8 mH
L303, 304	1-407-284	coil, dummy 1 mH
L305, 306	1-408-198	inductor, micro 2.2 mH

**CAPACITORS**

All capacitors are in  $\mu\text{F}$  unless otherwise indicated.  
pF:  $\mu\mu\text{F}$ , elect: electrolytic

C101, 201	1-105-681-12	0.047	50V	mylar
C102, 202	1-127-020	0.2	10V	elect
C103, 203	1-127-022	0.5	10V	elect
C104, 204	1-121-347	10	16V	elect
C105, 205	1-105-821-12	0.001	50V	mylar
C106, 206	1-121-347	10	16V	elect
C107, 207	1-121-291	100	6.3V	elect
C108, 208	1-121-287	47	3.15V	elect
C109, 209	1-121-347	10	15V	elect
C110, 210	1-121-289	47	25V	elect
C111, 211	1-121-347	1	50V	elect
C112, 212	1-121-284	33	6.3V	elect
C113, 213	1-105-687-12	0.15	50V	mylar
C114, 214	1-105-683-12	0.068	50V	mylar
C115, 215	1-105-678-12	0.027	50V	mylar
C116, 216	1-121-287	47	3.15V	elect
C117, 217	1-127-020	0.2	10V	elect
C118, 218	1-107-034	68p	500V	silvered mica
C119, 219	1-121-463	4.7	16V	elect
C120, 220	1-105-673-12	0.01	50V	mylar
C121, 221	1-105-674-12	0.012	50V	mylar
C122, 222	1-107-004	100p	500V	silvered mica
C123, 223	1-107-004	100p	500V	silvered mica
C124, 224	1-107-004	100p	500V	silvered mica
C125, 225	1-107-004	100p	500V	silvered mica
C126, 226	1-107-055	39p	500V	silvered mica
C127, 227	1-105-845-12	0.1	50V	mylar
C128, 228	1-105-827-12	0.033	50V	mylar
C152, 252	1-121-347	10	16V	elect
C153, 253	1-121-347	10	16V	elect
C154, 254	1-121-295	220	6.3V	elect
C155, 255	1-121-295	220	6.3V	elect
C156, 256	1-121-347	10	16V	elect
C157, 257	1-121-347	10	16V	elect



<u>Ref. No.</u>	<u>Part No.</u>	<u>Description</u>		
C158, 258	1-105-682-12	0.056	50V	mylar
C159, 259	1-105-667-12	0.0033	50V	mylar
C160, 260	1-121-293	100	25V	elect
C161, 261	1-131-134	1	25V	tantalum elect
C162, 262	1-121-343	1	50V	elect
C163, 263	1-105-667-12	0.0033	50V	mylar
C164, 264	1-105-661-12	0.001	50V	mylar
C165, 265	1-105-661-12	0.001	50V	mylar
C166, 266	1-107-140	270p	50V	silvered mica
C167, 267	1-121-284	33	6.3V	elect
C168, 268	1-121-468	10	6.3V	elect
C169, 269	1-121-287	47	3.15V	elect
C170, 270	1-121-281	4.7	25V	elect
C171, 271	1-121-343	1	50V	elect
C172, 272	1-121-343	1	50V	elect
C173, 273	1-121-283	10	25V	elect
C301, 401	1-105-825-12	0.0022	50V	mylar
C302, 402	1-105-835-12	0.015	50V	mylar
C303, 403	1-105-837	0.022	50V	mylar
C304, 404	1-105-845-12	0.1	50V	mylar
C305, 405	1-107-004	100p	500V	silvered mica
C306, 406	1-127-202	0.2	15V	elect
C307, 407	1-121-343	1	50V	elect
C308, 408	1-121-356	100	16V	elect
C309		-----		
C310, 410	1-121-343	1	50V	elect
C311, 411	1-121-343	1	50V	elect
C312, 412	1-121-356	100	16V	elect
C313, 413	1-105-821-12	0.0056	50V	mylar
C314, 414	1-105-821-12	0.0056	50V	mylar
C315, 415	1-107-005	220p	500V	silvered mica
C316, 416	1-121-361	500	35V	elect
C317, 417	1-127-202	0.2	15V	elect
C318, 418	1-107-051	15p	500V	silvered mica
C501, 502 C503	1-121-361	500	35V	elect
C601, 602	1-129-663	560p	50V	polyethylene
C603, 604	1-141-076	30~200p	500V	trimmer
C605	1-129-318	560p	500V	polyethylene
C606, 607	1-129-684	680p	50V	polyethylene
C608	1-105-823-12	0.0015	50V	mylar
C609	1-121-385	220	50V	elect
C651, 652	1-129-320	680p	500V	polyethylene
C653	1-105-839-12	0.033	50V	mylar
C654	1-117-036-22	1.5+0.5		metalized paper (E, AEP, UK)
C654	1-117-034-23	1.5		metalized paper (USA, Canada)
C655	1-121-524	2,200	50V	elect

<u>Ref. No.</u>	<u>Part No.</u>	<u>Description</u>
-----------------	-----------------	--------------------

**RESISTORS**

All resistors are in  $\Omega$ ,  $\frac{1}{4}W$  and carbon type unless otherwise indicated. k: 1,000, N: low noise

R101, 201	1-242-669	680
R102, 202	1-242-673	1 k
R103, 203	1-242-699	12 k
R104, 204	1-242-721-11	100 k
R105, 205	1-242-739	560 k
R106, 206	1-242-695	8.2 k
R107, 207	1-242-681	2.2 k
R108, 208	1-242-669	680
R109, 209	1-242-709	33 k
R110, 210	1-242-713-09	47 k (N)
R111, 211	1-242-697-09	10 k (N)
R112, 212	1-242-713-09	47 k (N)
R113, 213	1-242-713-09	47 k (N)
R114, 214	1-242-667	560
R115, 215	1-242-685-09	3.3 k (N)
R116, 216	1-242-713-11	47 k (N)
R117, 217	1-242-717-09	68 k (N)
R118, 218	1-242-705	22 k
R119, 219	1-242-683	2.7 k
R120, 220	1-242-681	2.2 k
R121, 221	1-221-748	5 k (B) adjustable
R122, 222	1-242-681	2.2 k
R123, 223	1-242-739	560 k
R124, 224	1-242-713-11	47 k (N)
R125, 225	1-242-685-11	3.3 k
R126, 226	1-242-721-11	100 k
R127, 227	1-242-665	470
R128, 228	1-242-705	22 k
R129, 229	1-242-715	56 k
R130, 230	1-242-677	1.5 k
R131, 231	1-242-665	470
R132, 232	1-242-681	2.2 k
R133, 233	1-242-695	8.2 k
R134, 234	1-244-689	4.7 k
R135, 235	1-222-209-14	200 k (C) variable
R136, 236	1-222-202-11	50 k (A) variable w/switch
R137, 237	1-242-641	47
R138, 238	1-242-677	1.5 k
R151, 251	1-242-673	1 k
R152, 252	1-242-739-09	560 k (N)
R153, 253	1-242-717-09	68 k (N)
R154, 254	1-242-721-09	100 k (N)
R155, 255	1-242-649	100
R156, 256	1-242-685-09	3.3 k (N)
R157, 257	1-242-717	68 k (N)
R158, 258	1-242-721-09	100 k (N)

<u>Ref. No.</u>	<u>Part No.</u>	<u>Description</u>
R159, 259	1-242-703	18 k
R160, 260	1-242-683	2.7 k
R161, 261	1-242-727	180 k
R162, 262	1-221-663-21	2 k (B) adjustable
R163, 263	1-221-320-21	3 k (B) adjustable
R164, 264	1-242-679	1.8 k
R165, 265	1-242-705	22 k
R166, 266	1-221-630-21	20 k (B) adjustable
R167, 267	1-242-735-09	390 k (N)
R168, 268	1-242-739-09	470 k (N)
R169, 269	1-242-713-09	47 k (N)
R170, 270	1-242-699	12 k
R171, 271	1-242-699	12 k
R172, 272	1-242-737-11	470 k
R173, 273	1-242-737-11	470 k
R174, 274	1-242-713-09	47 k (N)
R175, 275	1-242-731-09	270 k
R176, 276	1-242-727	180 k
R177, 277	1-242-695	8.2 k
R178, 278	1-242-665	470
R179, 279	1-242-711	39 k
R180, 280	1-242-679	1.8 k
R181, 281	1-242-679	1.8 k
R182, 282	1-242-669	680
R183, 283	1-242-705	22 k
R184, 284	1-242-703	18 k
R185, 285	1-221-311	5 k (B) adjustable
R186, 286	1-242-737-11	470 k
R187, 287	1-242-681	2.2 k
R188, 288	1-242-685-11	3.3 k
R301, 401	1-242-677	1.5 k
R302, 402	1-221-916-11	50 k (A) variable
R303, 403	1-242-695	8.2 k
R304, 404	1-221-916-11	50 k (A) variable
R305, 405	1-242-683	2.7 k
R306, 406	1-242-693	6.8 k
R307, 407	1-242-697	10 k
R308, 408	1-221-916-11	50 k (A) variable
R309, 409	1-242-699	12 k
R310, 410	1-242-719	82 k
R311, 411	1-242-723	120 k
R312, 412	1-242-693	6.8 k
R313, 413	1-242-709	33 k
R314, 414	1-242-709	33 k
R315, 415	1-242-641	47
R316, 416	1-242-683	2.7 k
R317, 417	1-242-683	2.7 k
R318, 418	1-242-669	680
R319, 419	1-242-720	91 k
R320, 420	1-242-689	4.7 k
R321, 421	1-242-625	10

<u>Ref. No.</u>	<u>Part No.</u>	<u>Description</u>
R322, 422	1-242-625	10
R323, 423	1-242-601	1
R324, 424	1-242-601	1
R325, 425	1-242-659	270
R326, 426	1-242-659	270
R327, 427	1-242-713	47 k
R328, 428	1-242-720	91 k
R329, 429	1-242-689	4.7 k
R330, 430	1-242-625	10
R331, 431	1-242-625	10
R332, 432	1-242-601	1
R333, 433	1-242-601	1
R334, 434	1-242-703	18 k
R335, 435	1-242-701	15 k
R336, 436	1-242-649	100
R337, 437	1-242-649	100
R338, 438	1-242-663	390
R339, 439	1-242-673	1 k
R340, 440	1-242-711	39 k
R341, 441	1-242-673	1 k
R342	1-222-208-11	100 k variable
R501	1-242-641	47
R502	1-242-649	100
R503	1-242-651	120
R601	1-242-635	27 k
R602	1-242-625	10
R603, 604	1-242-725	150 k
R605, 606	1-242-625	10
R651	1-222-119	200 k (A) variable w/switch
R652	1-244-709	33 k

**SWITCHES**

S101, 201	1-513-231	slide, record/playback
S102, 202	1-514-519	rotary, INPUT SELECTOR
S103, 203	1-514-416	rotary, TAPE SPEED & equalizer
S104, 204		included in resistor (R136, R236)
S105, 205	1-514-513	rotary, MONITOR
S106, 206	1-514-518	leaf, muting
S107, 207	1-514-515	rotary, NOISE SUPPRESS
S108, 208	1-514-520	slide, SP SELECTOR
S109, 209	1-514-515	rotary, MODE selector
S110, 210		included in jack (J302)
S301	1-514-416	rotary, equalizer
S302		included in variable resistor (R651)
S303	1-514-449	rotary, SOS

<u>Ref. No.</u>	<u>Part No.</u>	<u>Description</u>
S304	1-514-057	micro, bias shut-off
S305, 306	1-516-037	lever, POWER (USA)
S305, 306	1-514-325	lever, POWER (Canada, E)
S305	1-514-852	lever, POWER (AEP, UK)
S306	1-514-325	lever, POWER AMP (AEP, UK)
S307	1-514-039	micro, auto-shut-off
S308	1-514-512	rotary, frequency selector (E, AEP, UK)

**JACKS**

J101, 201	1-507-142	2P phono, PHONO
J102, 202	1-507-142	2P phono, TUNER
J103, 203	1-507-142	2P phono, AUX
J104, 204	1-507-266	phone, MIC
J105, 205	1-507-142	2P phono, LINE
J106, 206	1-507-142	2P phono, EXT SP
J107, 207	1-507-107	phone, LID SP
J301	1-507-187	binaural, HEADPHONE MONITOR
J302	1-507-190	binaural, w/switch; HEADPHONE LISTEN
CNJ301, CNJ302	1-509-015-01	connector (E, USA, Canada)
CNJ303	1-509-029	connector, REC/PB (E, AEP, UK)
CNP301	1-509-062	connector (E, USA, Canada)

**MISCELLANEOUS**

REC.	8-821-229-01	head, playback; PP30-2902A
H101, 201	8-829-129-20	head, playback; PP102-2902 (Serial No. 124,761 )

<u>Ref. No.</u>	<u>Part No.</u>	<u>Description</u>
PB.	8-824-129-20	head, record; RP30-2902
H101, 201	8-824-629-20	head, record; RP102-2902 (Serial No. 124,701~)
EH101, 201	8-826-629-24	head, erase; EF18-2902A
M	8-832-624-09	motor IC-624HI
SP101, 201	1-502-211	speaker
VS	1-509-064	voltage selector (E, AEP)
PL101, 201, PL301, 302	1-518-093	lamp
	1-534-153-13	cord, power; w/plug (AEP)
	1-534-819-00	cord, power; w/plug (UK)
PL303, 304		included in VU meter (ME101, 201)
ME101, 201	1-524-056-13S	meter, VU w/lamp
CP301	1-101-534	encapsulated component 0.1 $\mu$ F + 120 $\Omega$
CP302	1-231-057	encapsulated component 0.033 $\mu$ F + 120 $\Omega$
	1-533-048	holder, fuse (E, USA, Canada)
F1	1-532-204	fuse 2A (AEP, UK)
F	1-532-100-11	fuse 2A (E)
F1	1-532-268-11	fuse 2A (Canada)
F1	1-532-338-11	fuse 2A (USA)
F2,5,6	1-532-078-11	fuse 1AT (AEP, UK)
F3,4	1-532-074-11	fuse 160mAT (AEP, UK)
	1-533-026-11	holder, fuse; 3P (AEP, UK)
	1-536-376	terminal strip, 1-L-1
	1-536-145	terminal strip, L-1
	1-536-179	terminal strip, 1-L-1
	1-506-024	cord w/plug

## SECTION 8 HARDWARE







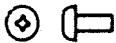

<u>Part No.</u>	<u>Description</u>	<u>Part No.</u>	<u>Description</u>
<b>SCREWS</b>			
7-621-255-25	RF 2 x 4 (E, AEP, UK)	7-682-549-01	B 3 x 10
7-621-255-35	RF 2 x 5 (E, AEP, UK)	7-682-549-13	B 3 x 10
7-621-255-45	RF 2 x 6 (E, AEP, UK)	7-682-550-13	B 3 x 12
7-621-255-55	RF 2 x 8 (E, AEP, UK)	7-682-581-14	B 5 x 30
7-621-259-12	RF 2.6 x 3 (E, AEP, UK)	7-683-237-01	3 x 3, self-tapping
7-621-259-15	RF 2.6 x 3 (E, AEP, UK)	<b>WASHERS</b>	
7-621-259-22	RF 2.6 x 4 (E, AEP, UK)	7-623-107-02	2.6 (small)
7-621-259-32	RF 2.6 x 5 (E, AEP, UK)	7-623-107-12	2.6
7-621-259-35	RF 2.6 x 5 (E, AEP, UK)	7-623-108-02	3 (small)
7-621-259-45	RF 2.6 x 6 (E, AEP, UK)	7-623-108-12	3
7-621-510-32	(-)K 2.6 x 22 (E, AEP, UK)	7-623-108-18	3
7-621-559-42	K 2.6 x 22 (E, AEP, UK)	7-623-108-22	3 (large)
7-621-659-47	RK 2.6 x 6 (E, AEP, UK)	7-623-110-02	4 (small)
7-621-712-56	(-)SC 2.6 x 6 (E, AEP, UK)	7-623-112-12	5 (t=0.8)
7-621-712-66	(-)SC 2.6 x 8 (E, AEP, UK)	7-623-112-16	5 (t=0.4)
7-621-844-29	R 3.1 x 8, wood (E, AEP, UK)	7-623-205-22	2 spring
7-621-852-17	K 2.7 x 8, wood (E, AEP, UK)	7-623-207-22	2.6 spring
7-621-852-38	K 2.6 x 10, wood (E, AEP, UK)	7-623-208-22	3 spring
7-682-145-01	P 3 x 4	7-623-210-22	4 spring
7-682-146-01	P 3 x 5	7-623-308-05	3 internal tooth
7-682-147-01	P 3 x 6	7-623-408-05	3 external tooth
7-682-148-01	P 3 x 8	<b>MISCELLANEOUS</b>	
7-682-149-01	P 3 x 10	7-622-307-07	nut 2.6
7-682-150-01	P 3 x 12	7-684-013-01	nut 3
7-682-151-01	P 3 x 14	7-684-014-01	nut 4
7-682-152-01	P 3 x 16	7-622-308-02	lug 3
7-682-154-13	P 3 x 25 (AEP, UK)	7-623-508-01	lug 3
7-682-169-01	P 4 x 6	7-623-510-01	lug 4
7-682-161-01	P 4 x 8	7-624-106-01	retaining ring E 3
7-682-165-14	P 4 x 6	7-624-108-01	retaining ring E 4
7-682-247-14	K 3 x 6	7-624-109-01	retaining ring E 5
7-682-248-01	K 3 x 8	7-629-100-86	nail 1 x 6
7-682-348-14	RK 3 x 8		
7-682-547-13	B 3 x 6		
7-682-547-14	B 3 x 6		
7-682-548-13	B 3 x 8 (E, UK)		

**Note:** 1. All screws are Phillips type (cross recess type) unless otherwise indicated.

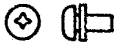
(-): slotted head

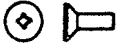
For Service Manuals  
**MAURITRON SERVICES**  
 8 Cherry Tree Road, Chinnor  
 Oxfordshire, OX9 4QY.  
 Tel (01844) 351694  
 Fax (01844) 352554  
 email:- mauritron@dial.pipex.com

— Hardware Nomenclature —

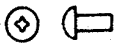
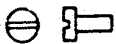
<b>P</b> - Pan Head Screw .....		<b>SC</b> - Set Screw .....	
<b>PS</b> - Pan Head Screw with Spring Washer .....		<b>E</b> - Retaining Ring (E Washer) .....	
<b>K</b> - Flat Countersunk Head Screw .....		<b>W</b> - Washer	
<b>B</b> - Binding Head Screw .....		<b>SW</b> - Spring Washer	
<b>RK</b> - Oval Countersunk Head Screw .....		<b>LW</b> - Lock Washer	
<b>T</b> - Truss Head Screw .....		<b>N</b> - Nut	
<b>R</b> - Round Head Screw .....			
<b>F</b> - Flat Fillister Head Screw .....			

— Example —

⊕ P 3×10

- └─ Type of Slot
- └─ Length in mm (L)
- └─ Diameter in mm (D)
- └─ Type of Head

